

HELLO  
From BMT



# Table Of Contents

---

ABOUT

Leadership · History · Clients · Organization · Location

WHAT WE DO

Brand Experience Marketing · Public Service Design · Video Contents Production

HOW TO DO

# ABOUT

---



Established in 2008, BMT is a specialized production company that has realized brand value based on experience and technical expertise.

We have accumulated extensive experience in the fields of shows, exhibitions, events, special structures, video content, and manufacturing industries.

BMT combines creative thinking with technology. We do not let creative ideas remain merely ideas.

We bring ideas to reality through cutting-edge technology and deliver differentiated results based on professional production know-how and field experience.

Leveraging our skilled workforce and stable production system, we successfully execute projects of various scales, delivering the quality and level of perfection required by our clients.

Possessing the capability to produce video content for brand promotion and marketing, we provide a brand experience that spans both online and offline platforms.

BMT is always ready to deliver the best results to your company.

# LEADERSHIP

---



FOUNDER / CEO  
**Byeongmoo Park**

Only with his ambition and enthusiasm, Byeongmoo Park established BMT in 2008 at the age of 25 by leading the technology and trend of the industry, with his creative ideas, he has created customized fixtures for each exhibit and switched the trend to lead the industry which was mostly focused on engineering. As the leader of BMT Co Ltd., and a pioneer of the industry, he accomplished various projects successfully such as the Samsung retail shop highlight, Hyundai motors experience facilities, Yeosu Expo sculptures and so on.



COO  
**Seongken Yoo**

Since 2005, Seongken Yoo has accumulated know-how in commercial film production by conducting various TV-CF projects ranging from automobiles, cosmetics, and apartment items to telecommunication, food, and confectionery items. Since 2011, he has planned/produced branded films in various fields in Brand Experience section of Cheil Worldwide. He is familiar with both traditional and new experiments, and has always been looking for the best solution. This experience led him to join BMT's video planning/production division as Executive Producer.

# HISTORY

---

SAMSUNG



HYUNDAI  
MOTOR GROUP

NETFLIX



LOTTE



Cheil

INNOCEAN

HYUNDAI  
MOBIS

KRAFTON



SAMYANG

XREAL

kotra  
Korea Trade-Investment  
Promotion Agency

국순당

# AWARDS

---



## IF Design Award

2024 Genesis CMF Experience  
2019 Samsung, Inspired by you  
2018 CES Samsung City



## NY Festival

2024 Diablo IV\_Hell Station,  
Avant-Garde / Innovative Shortlist



## RedDot Design Award

2018 Samsung Inspired by you



## The One Show

Diablo IV\_Hell Station, Design : Spatial Design Shortlist  
Diablo IV\_Hell Station, Gaming : Game Marketing Merit



## Korea Advertising

Awarded for 2 consecutive years  
2024 Kooksoondang Bekseju Brand film & Offline Promotion  
2023 Diablo IV\_Hell Station, OOH Bronze  
2023 Diablo IV\_Hell Station Promotion Grand Prize



## Spikes Asia

2024 Diablo IV\_Hell Station, Design Shortlist  
2024 Brand Experience & Activation Shortlist



## MadStars

2024 Diablo IV\_Hell Station,  
Brand Experience & Activation Stars  
2024 Strategy Stars Silver



## ADFEST

Diablo IV\_Hell Station, Brand Experience Strategy  
: Launch / Re-Launch Bronze  
Diablo IV\_Hell Station, Brand Experience Use of Media  
: Ambient/Large Scale Silver

# AWARDS

---

2012 NYFestival	PyeongChang 2018_Heroes, Film & Video <b>Gold</b>
2019 IF Design Award	2018 CES Samsung City, Exhibition booth design <b>Design</b>
2019 IF Design Award	Samsung Inspired by You, Exhibition Design <b>Gold</b>
2023 KOREA ADVERTISING AWARDS	Diablo IV_Hell Station Promotion <b>Grand Prize</b>
2023 KOREA ADVERTISING AWARDS	Diablo IV_Hell Station, OOH <b>Bronze</b>
2024 KOREA ADVERTISING SOCIETY	Diablo IV_Hell Station, OOH0/SP Advertising <b>Grand Prize</b>
2024 ADFEST	Diablo IV_Hell Station, Brand Experience Use of Media : Ambient/Large Scale <b>Silver</b>
2024 ADFEST	Diablo IV_Hell Station, Brand Experience Strategy : Launch / Re-Launch <b>Bronze</b>
2024 The One Show	Diablo IV_Hell Station, Gaming : Game Marketing <b>Merit</b>
2024 The One Show	Diablo IV_Hell Station, Design : Spatial Design <b>Shortlist</b>
2024 Spikes Asia	Diablo IV_Hell Station, Brand Experience & Activation <b>Shortlist</b>
2024 Spikes Asia	Diablo IV_Hell Station, Design <b>Shortlist</b>
2024 NYFestival	Diablo IV_Hell Station, Avant-Garde / Innovative <b>Shortlist</b>
2024 MadStars	Diablo IV_Hell Station, Strategy Stars <b>Silver</b>
2024 MadStars	Diablo IV_Hell Station, Brand Experience & Activation Stars <b>Bronze</b>
2024 KOREA ADVERTISING AWARDS	Kooksoondang Bekseju Brand Film '어른찬가', Online Long Film <b>Grand Prize</b>
2025 YouTube Works Awards	Kooksoondang Bekseju Brand Film '어른찬가' & Experience '백세주막', <b>Best Brand Experience</b>
2025 YouTube Works Awards	Kooksoondang Bekseju Brand Film '어른찬가' & Experience '백세주막', <b>Grand Prize</b>



**WHAT**

**WE**

**DO**

# **Brand Experience Marketing**

2026

FIDAE HANHWA

In Chile



# Hanwha

 Hanwha

LAND

LAND

SPACE

SPACE

NAVAL

NAVAL

SMART BATTLESHIP

SUBMARINE CMS

CHUNMO

K9 ARTILLERY

0.25M

STELLITE

# TIGON



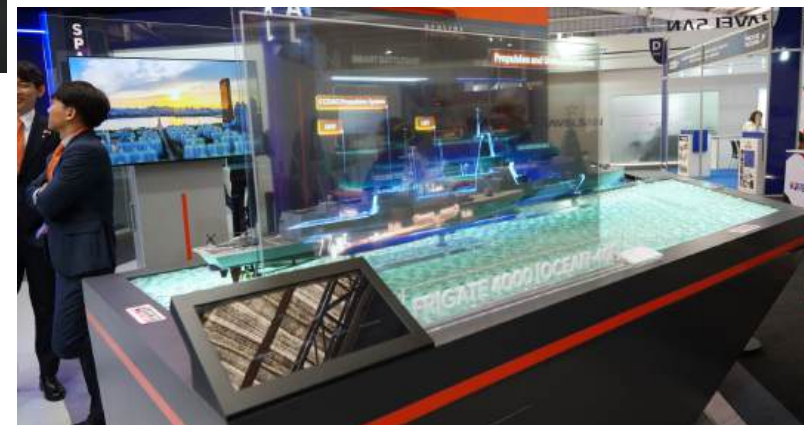
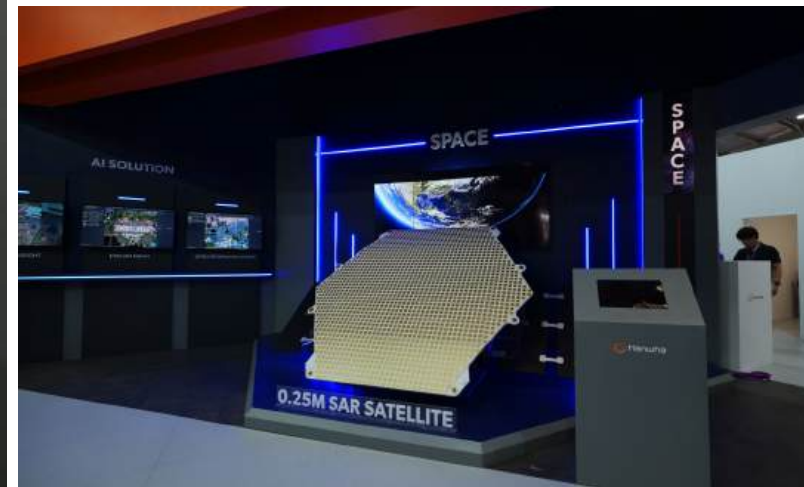

**Experience & Space 2026  
development for Hanhwa  
FIDAE 2026 in Santiago, Chile**

# 2026 Hanwha Aerospace Showroom



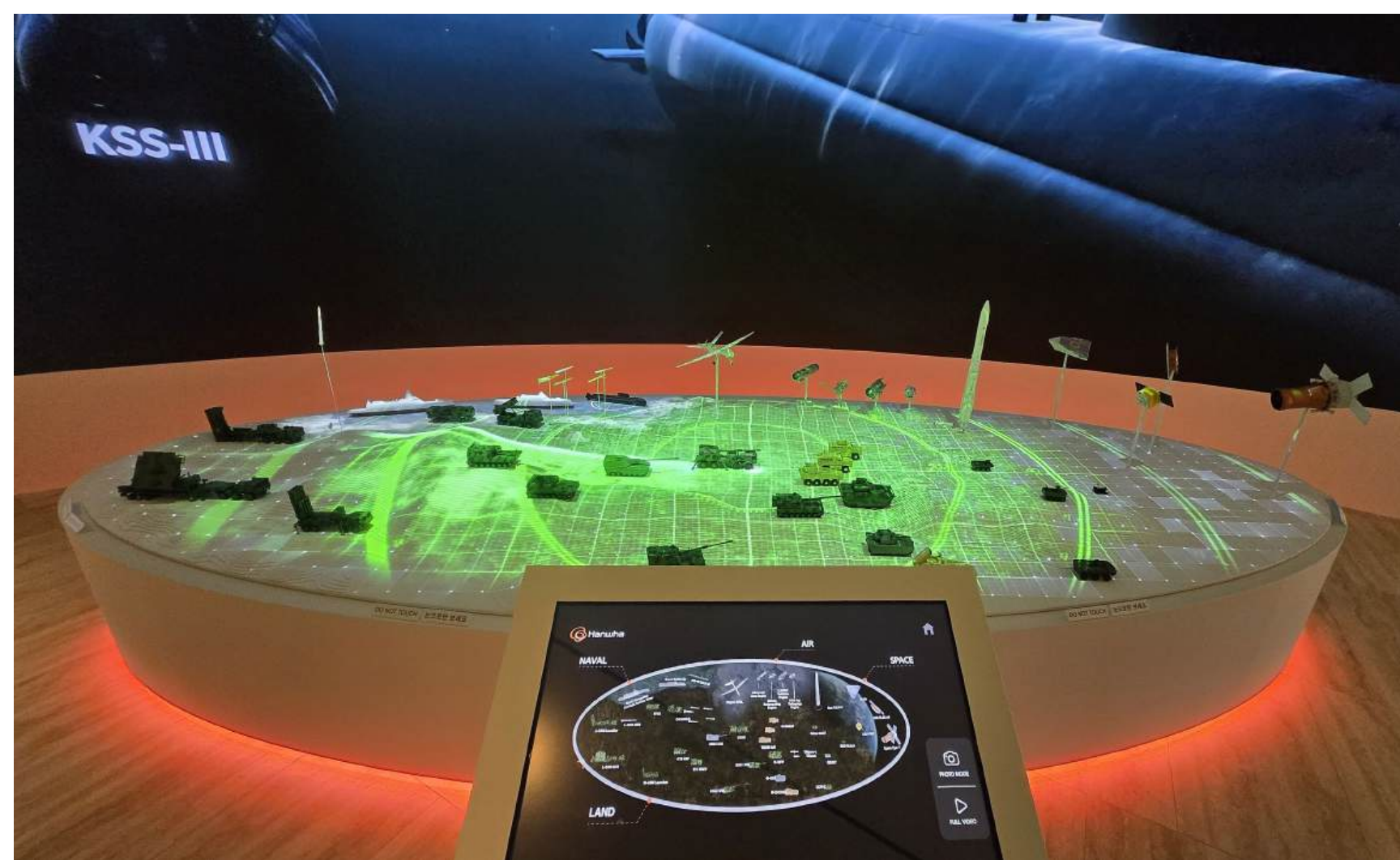

Models & Space  
development for Hanwaha  
2026

2025

KIA Geumcheon  
CMF Table





**Models 2025  
development for KIA  
Furniture Manufacturing and Delivery**

# 2025 KIA Geumcheon



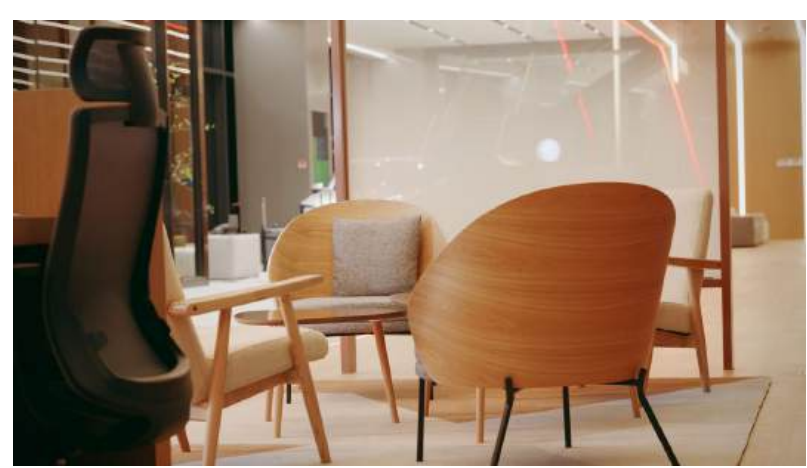
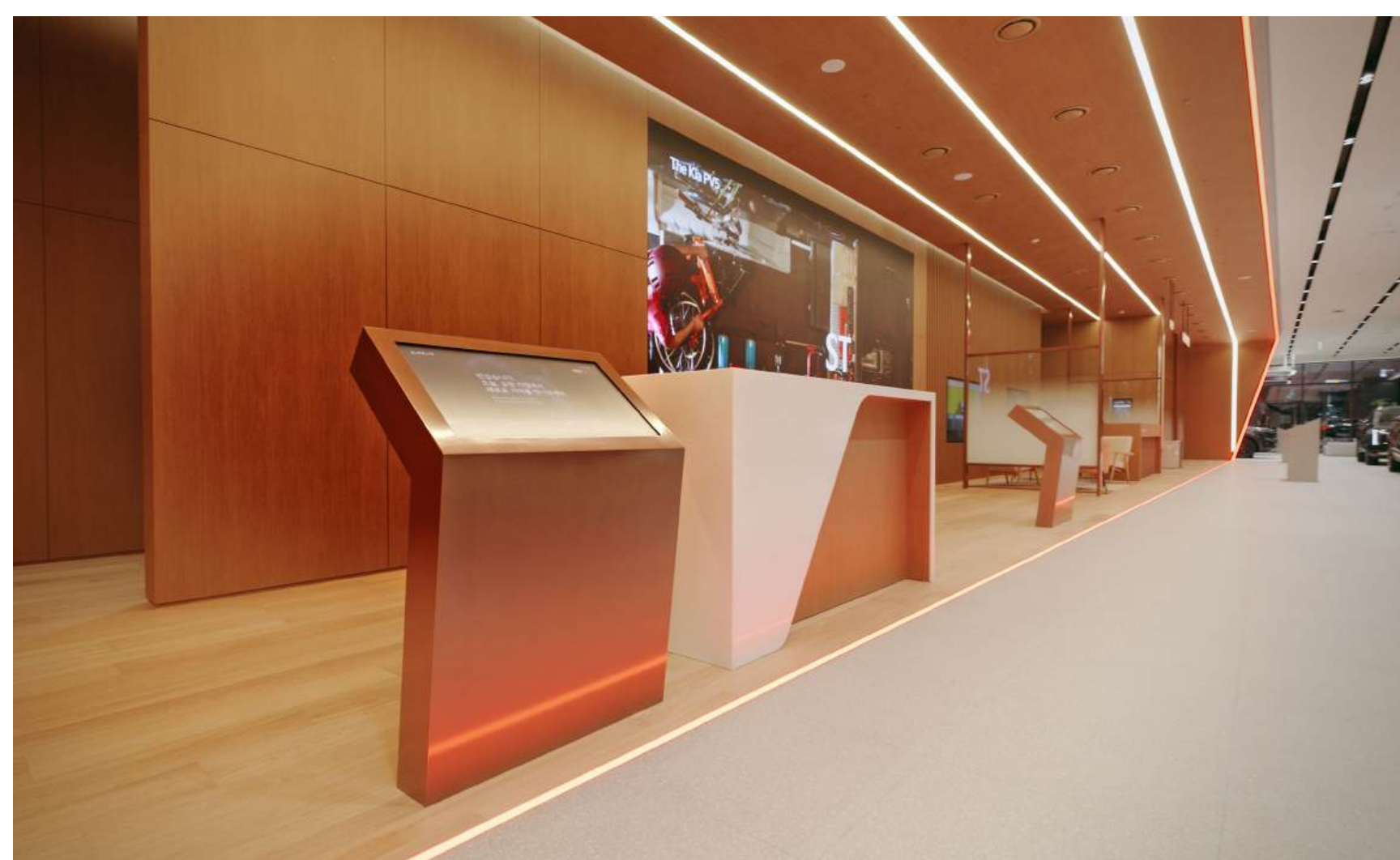

**Furniture Production  
& Procurement  
for KIA Geumcheon 2025**

# 2025 KIA PBV Experience Center

Long

The Kia PV5 카고

The Kia PV5 Cargo Long

The Kia PV5 Passenger



# PBV Materials

## PV5 Exterior



## PV5 Interior

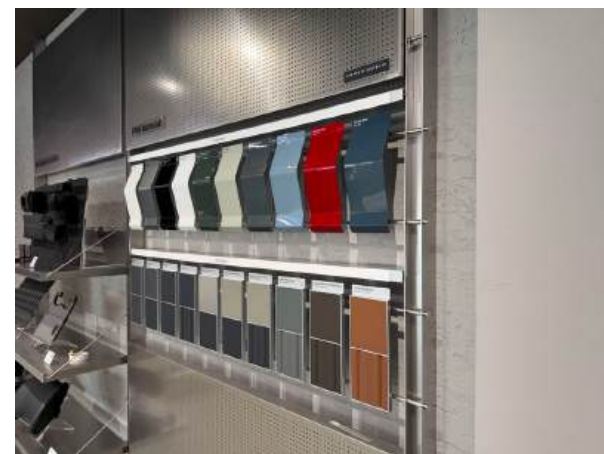
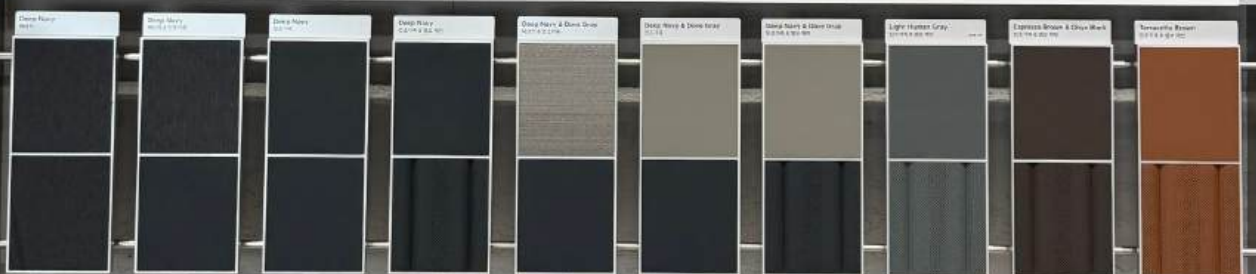

CMF Wall  
for KIA PBV Experience Center  
2025

# 2025 UHR SAR SATELLITE VIP PACKAGE

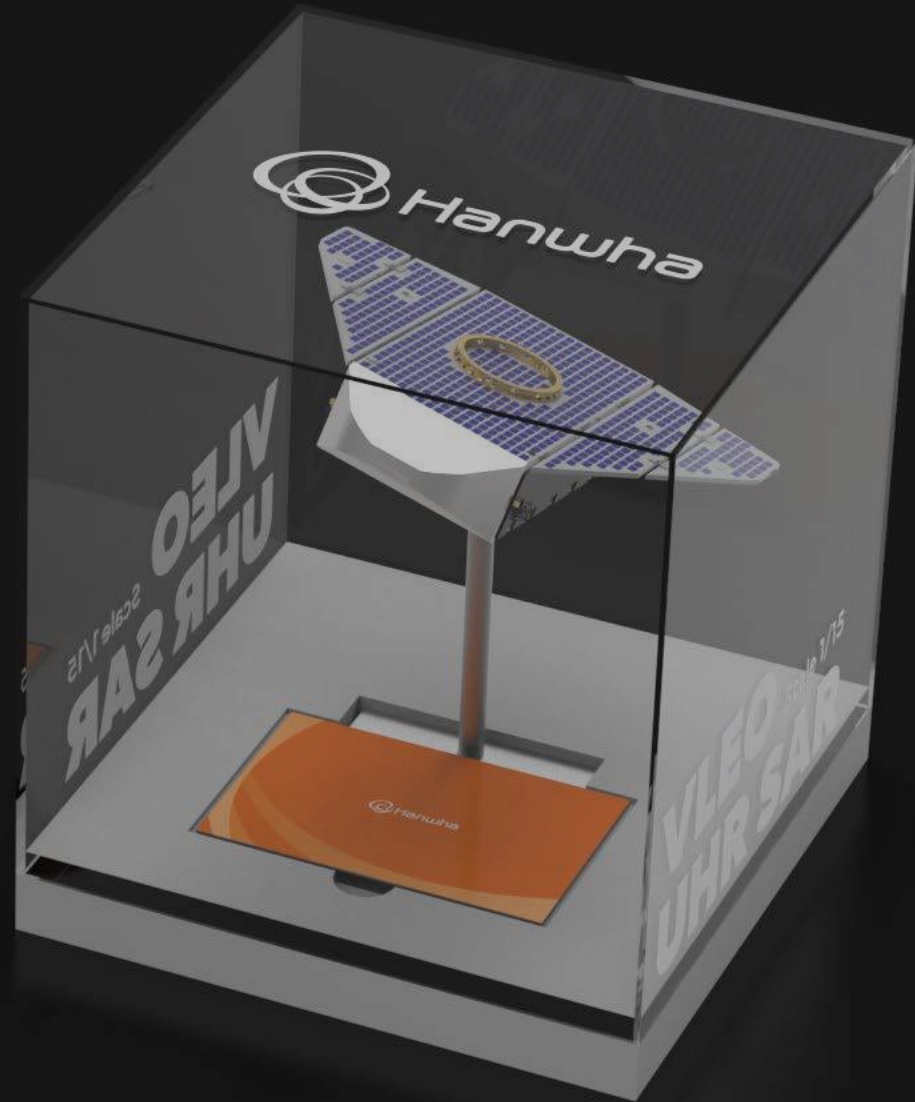
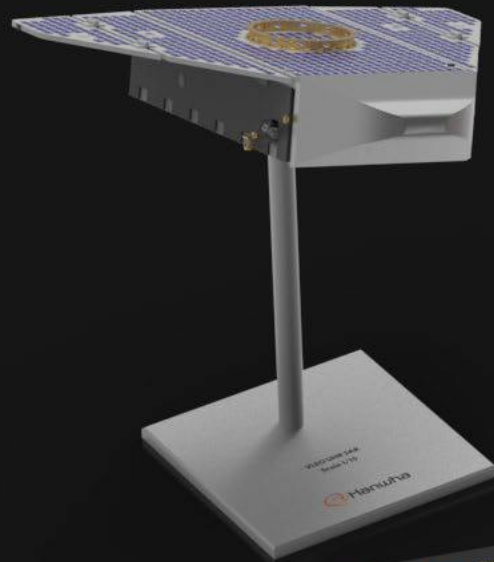

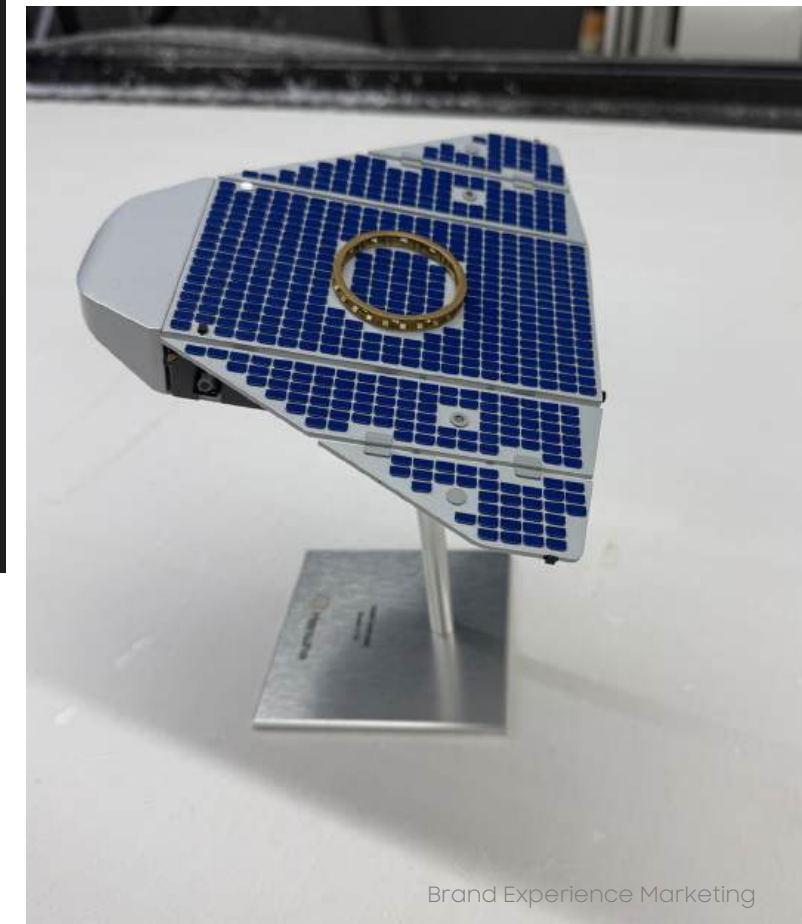
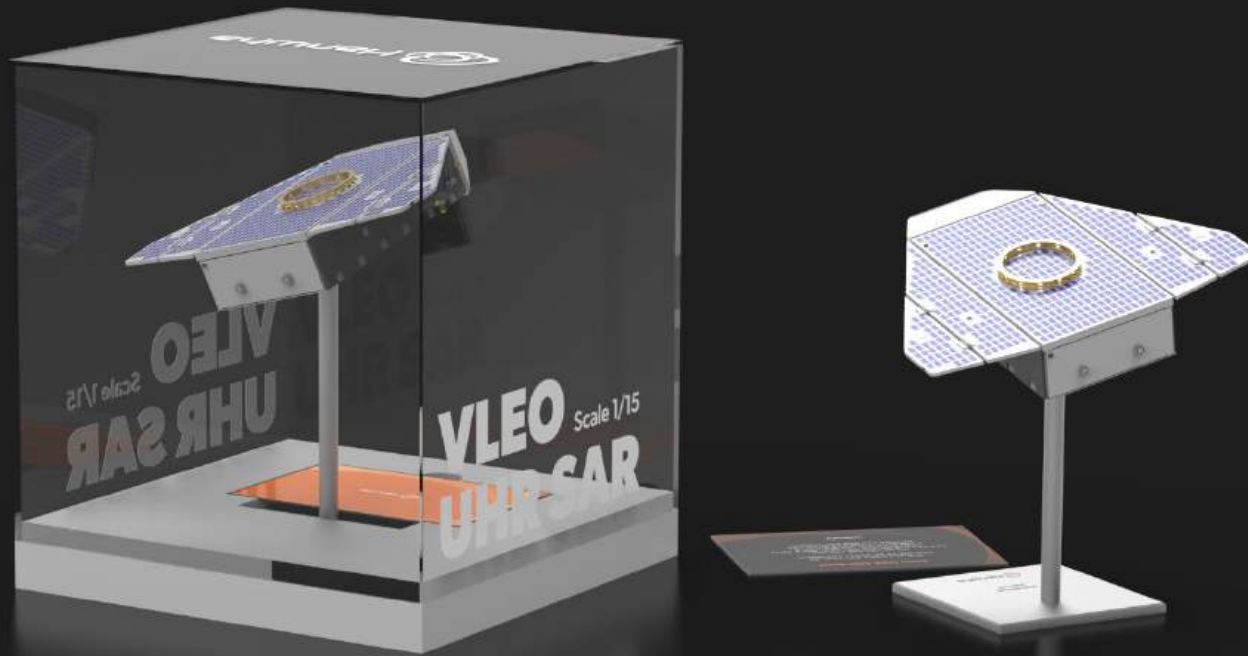

**Models 2025  
development for KIA  
Furniture Manufacturing and Delivery**

2025

# ADEX Hanwha





Modles & Space  
development for Hanwha  
2025

# APEC 2025

2025 APEC CEO SUMMIT

Hanwha Future Tech Forum: Defense  
Sustainable Peace for All

APEC

# KOREA

# In Gyeongju



# Hanwha

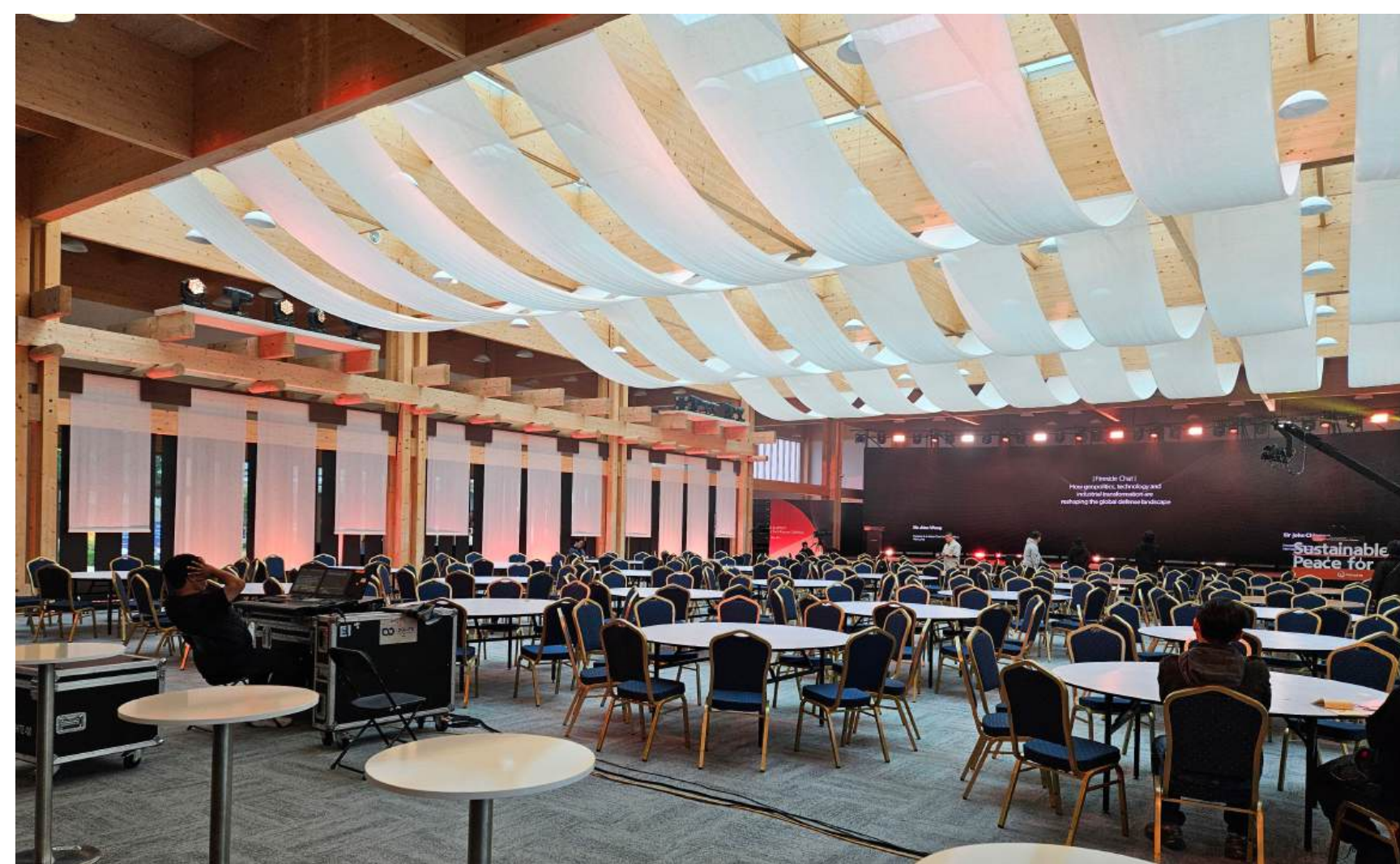

## Experience & Space development for Hanwha 2025 in Gyeongju

2025

W CONCEPT

POP-UP





Experience & Space  
development for W CONCEPT  
2025 in Seoul

# 2025

## GREENCHIPS HOTEL

# GREENCHIPS

# FESTIVAL

WELCOME TO  
GREENCHIPS TOWN HOTEL

Check-in to Sustainable Design  
지속가능한 디자인을 만나는 그린칩스 호텔에 체크인하세요!

POP-UP

10.15(Wed) - 10.29(Sun)  
10:00 - 20:00

오늘도 지속가능한 하루 보내세요!  
EVERYDAY GREENCHIPS

TOWN  
GREENCHIPS  
FESTIVAL

# GREENCHIPS HOTEL



**WELCOME TO GREENCHIPS TOWN HOTEL**

Check-in to Sustainable Design  
지속가능한 디자인을 만나는 그린칩스 호텔에 체크인하세요!

**POP-UP**

10.15(Wed) - 10.29(Sun)  
10:00 - 20:00

오늘도 지속가능한 하루 보내세요!  
EVERYDAY GREENCHIPS

GREENCHIPS FESTIVAL

Experience & Space development for GREENCHIPS FESTIVAL in Seoul



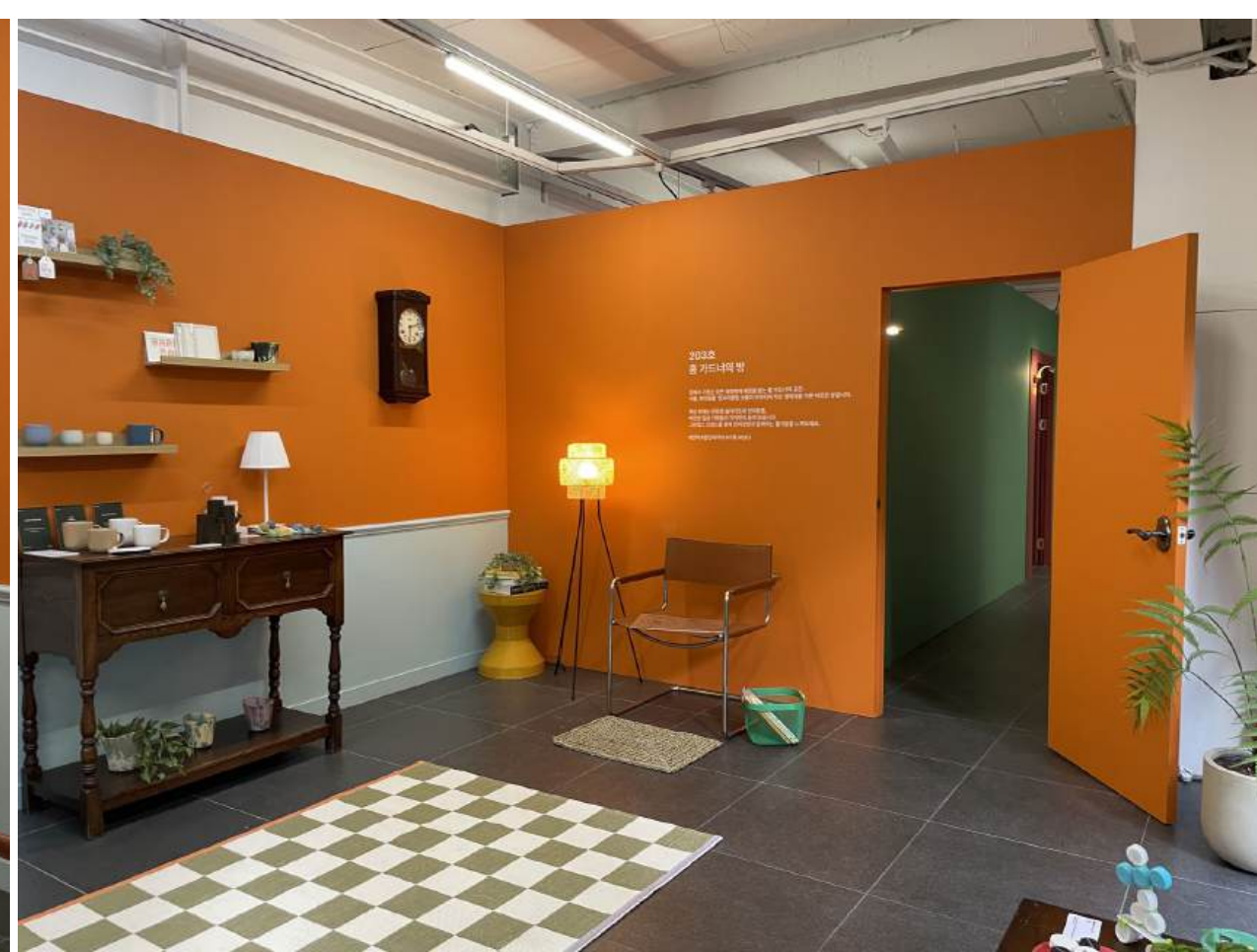

## Experience & Space development for GREENCHIPS FESTIVAL in Seoul





## Experience & Space development for GREENCHIPS FESTIVAL in Seoul



## Experience & Space development for GREENCHIPS FESTIVAL in Seoul

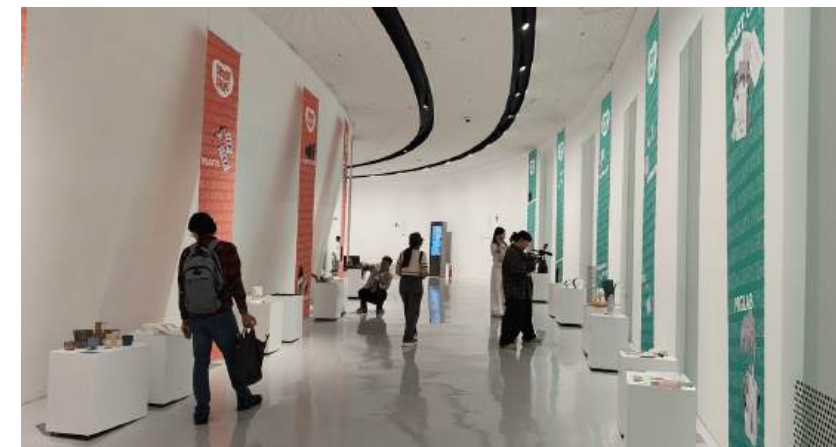

2025

OLIVE YOUNG

FESTA

2025  
OLIVE YOUNG  
FESTA





**Models  
development for CJ OLIVE YOUNG  
FESTA 2025 in Seoul Nodeul island**

# 2025

# RAINBOW 6

# POP UP

TOM CLANCY'S  
RAINBOW 6

# SIEGE X

레인보우 식스 시즈 맥스

A UBISOFT ORIGINAL



금연  
쓰레기투기 금지  
위반 시 과태료 부과  
스타벅스 강남에비뉴점  
STARBUCKS

쓰레기투기  
위반 시  
스타벅스  
STARBUCKS



Experience & Space development for Rainbow 6 Siege X 2025 in Seoul

# 2025 MONOFLEX POP-UP





**Models 2025  
MONOFLEX Gallery  
POP-UP**

2025

HANWHA

IDEX

 Hanwha





**Contents & Sketch 2025  
development for Hanwha  
IDEX 2025 in Dubai**

# 2025 Samsung Galaxy Studio



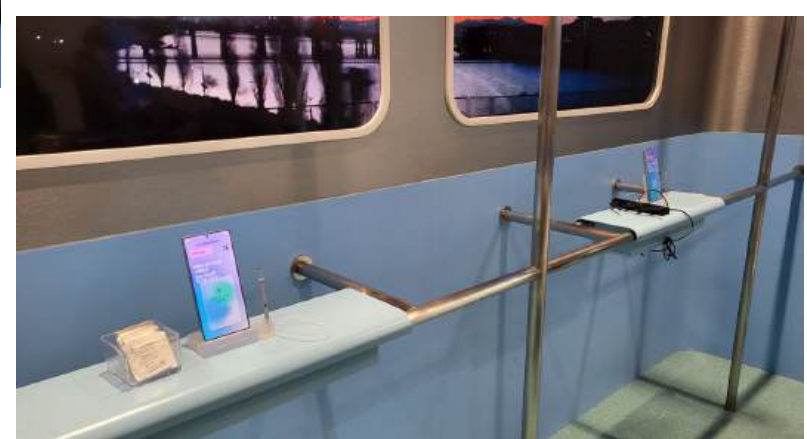
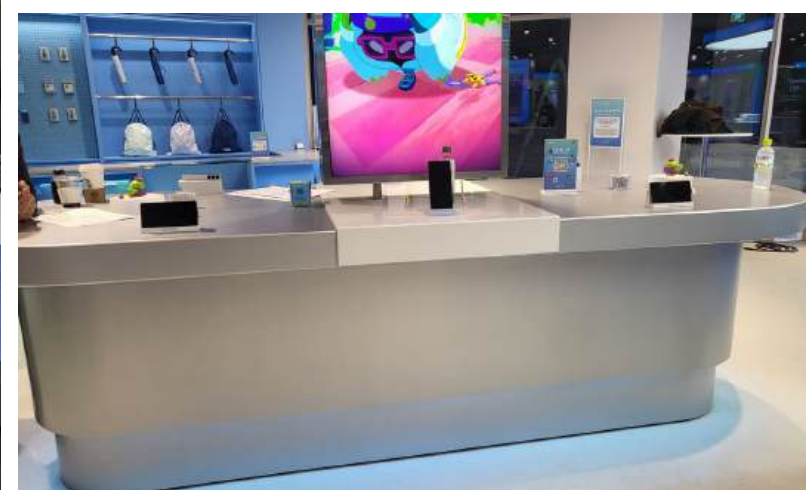
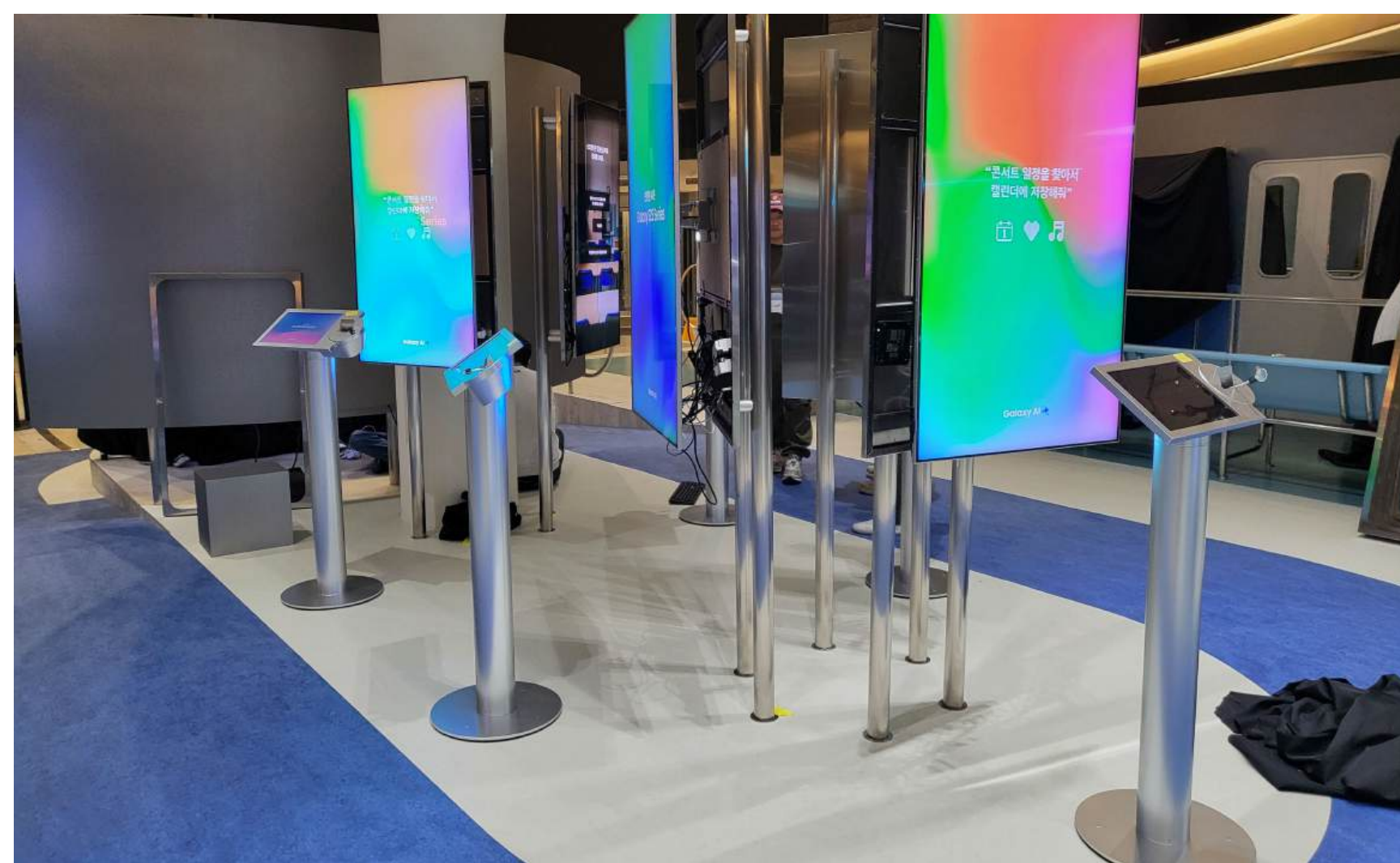

**Models 2025**  
**Samsung Galaxy Studio**

# 2025 CES Samsung GMO



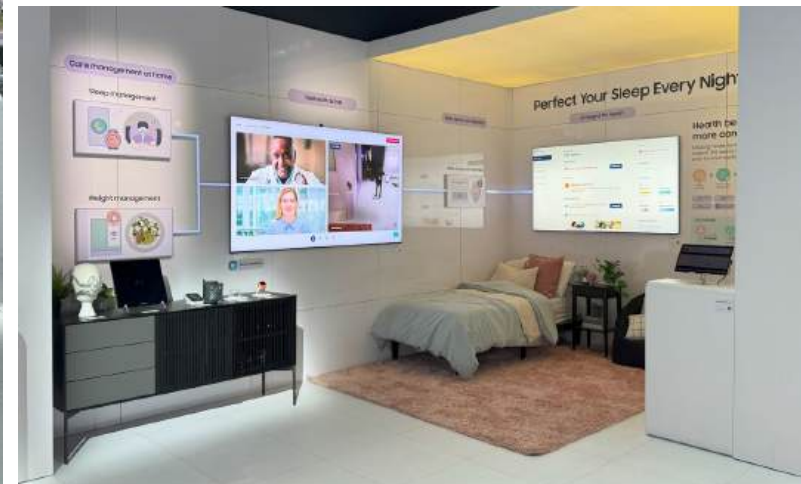
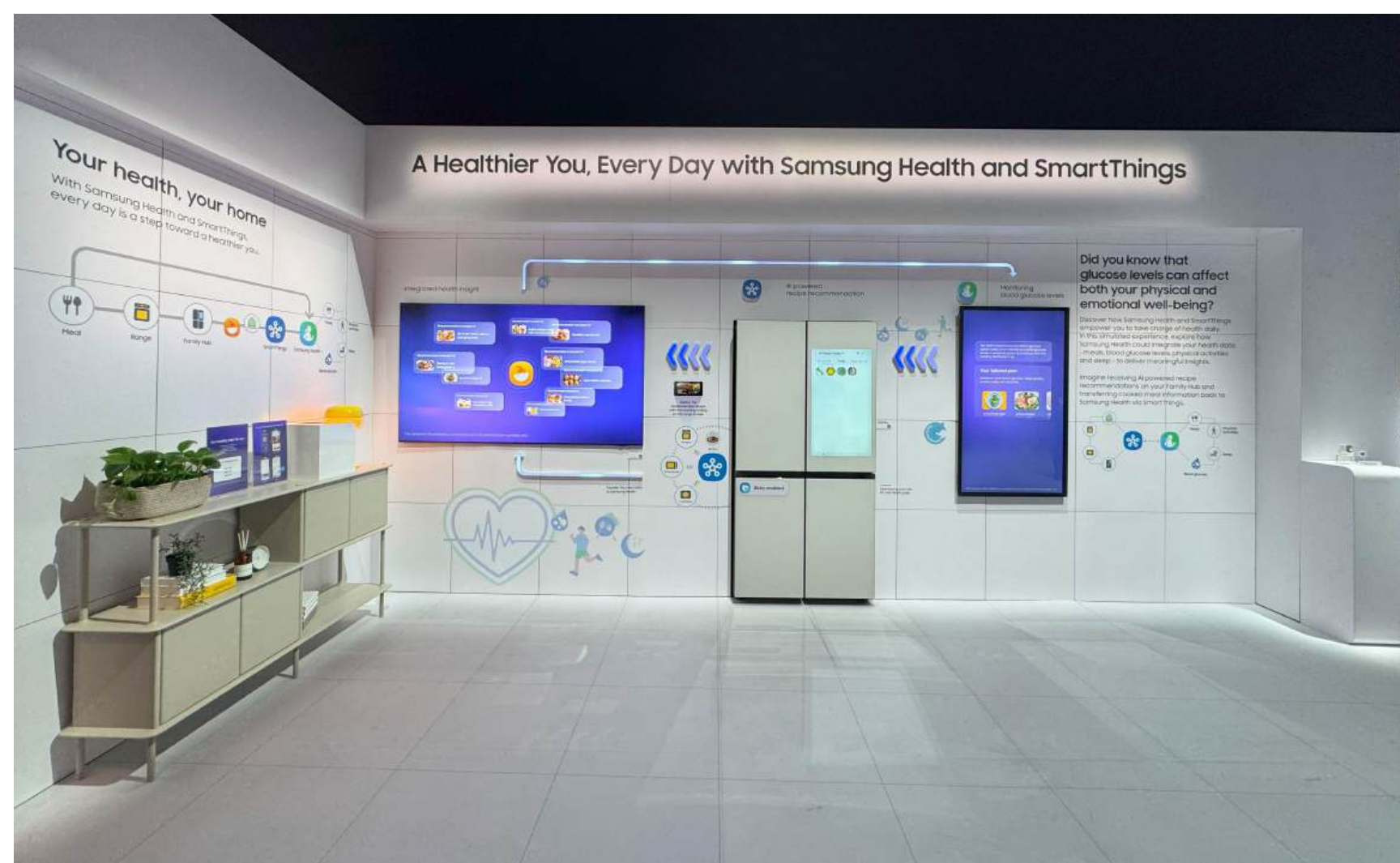

Experience & Space  
development for CES 2025  
Samsung GMO

# Kooksoondang Bekseju Pop-up 2024



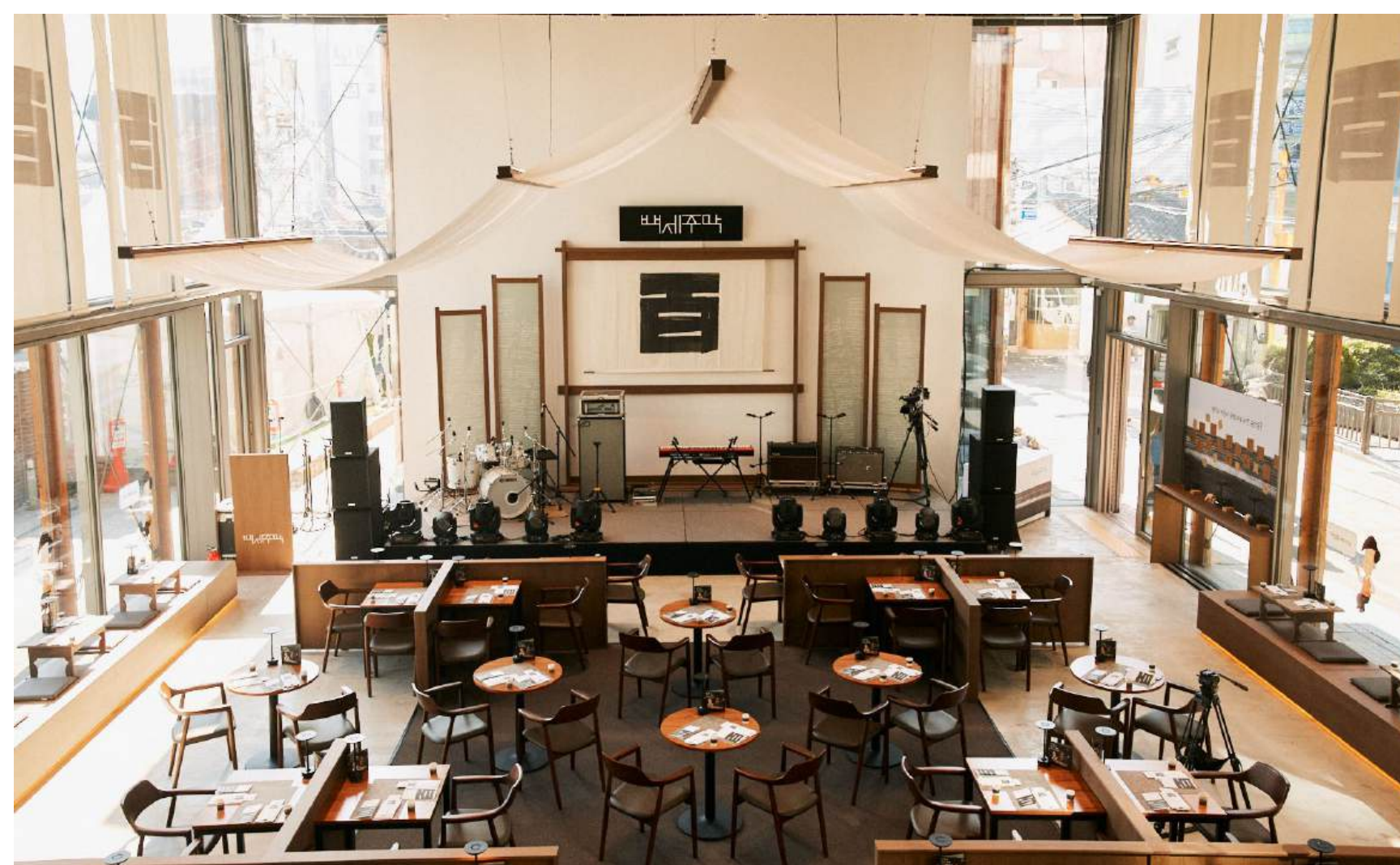

## Experience & Space development for Kooksoondang Bekseju 2024 in Seoul

# 2024 HD Hyundai Brand Goods Shop

The image shows the interior of a retail store. The space is bright and modern, featuring white walls and a light-colored tiled floor. Track lighting is installed on the ceiling, providing focused illumination. On the left, there are white shelves displaying various products, including books and small figurines. In the center, a large display case contains a detailed model of a construction site with cranes and buildings. To the right, there are more display cases and shelves, some containing kitchenware like a green mug and a yellow pitcher. The overall aesthetic is clean and organized.



**Experience & Space  
development for HD Hyundai  
Brand Goods Shop 2024**

# 2024 Samsung Gangnam





## Experience & Space & Models development for Samsung Gangnam Flagship Store 2024

# 2024 ADIPEC Samsung E&A

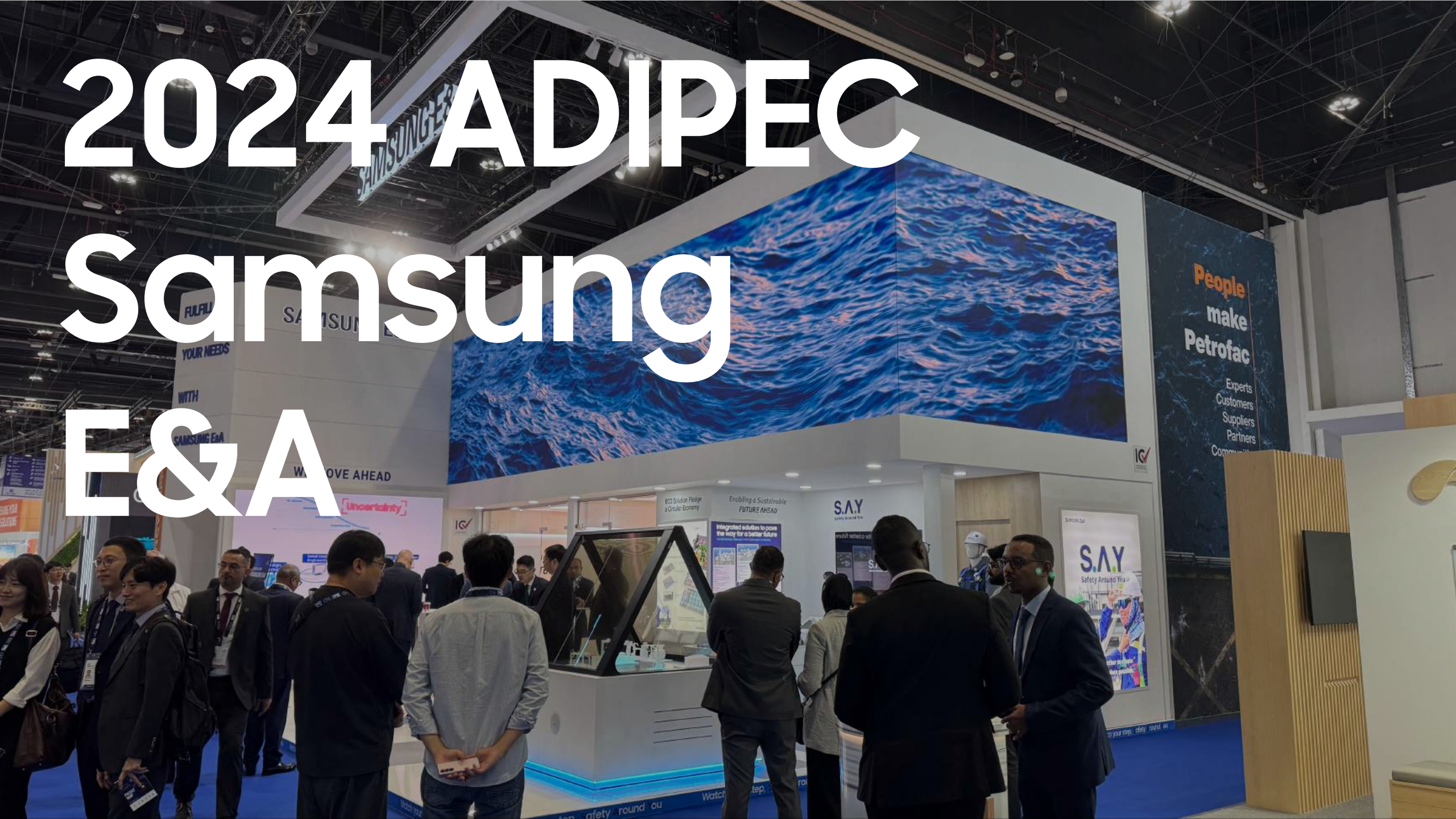

FUJIFILM  
YOUR NEEDS  
WITH  
SAMSUNG E&A  
WE MOVE AHEAD



**People make Petrofac**  
Experts  
Customers  
Suppliers  
Partners  
Communities



Enabling a Sustainable FUTURE AHEAD

S.A.Y. Safety Around You





**Models 2024 ADIPEC  
development for  
Samsung E&A Diorama**

# 2024 Samsung E&A Hot box

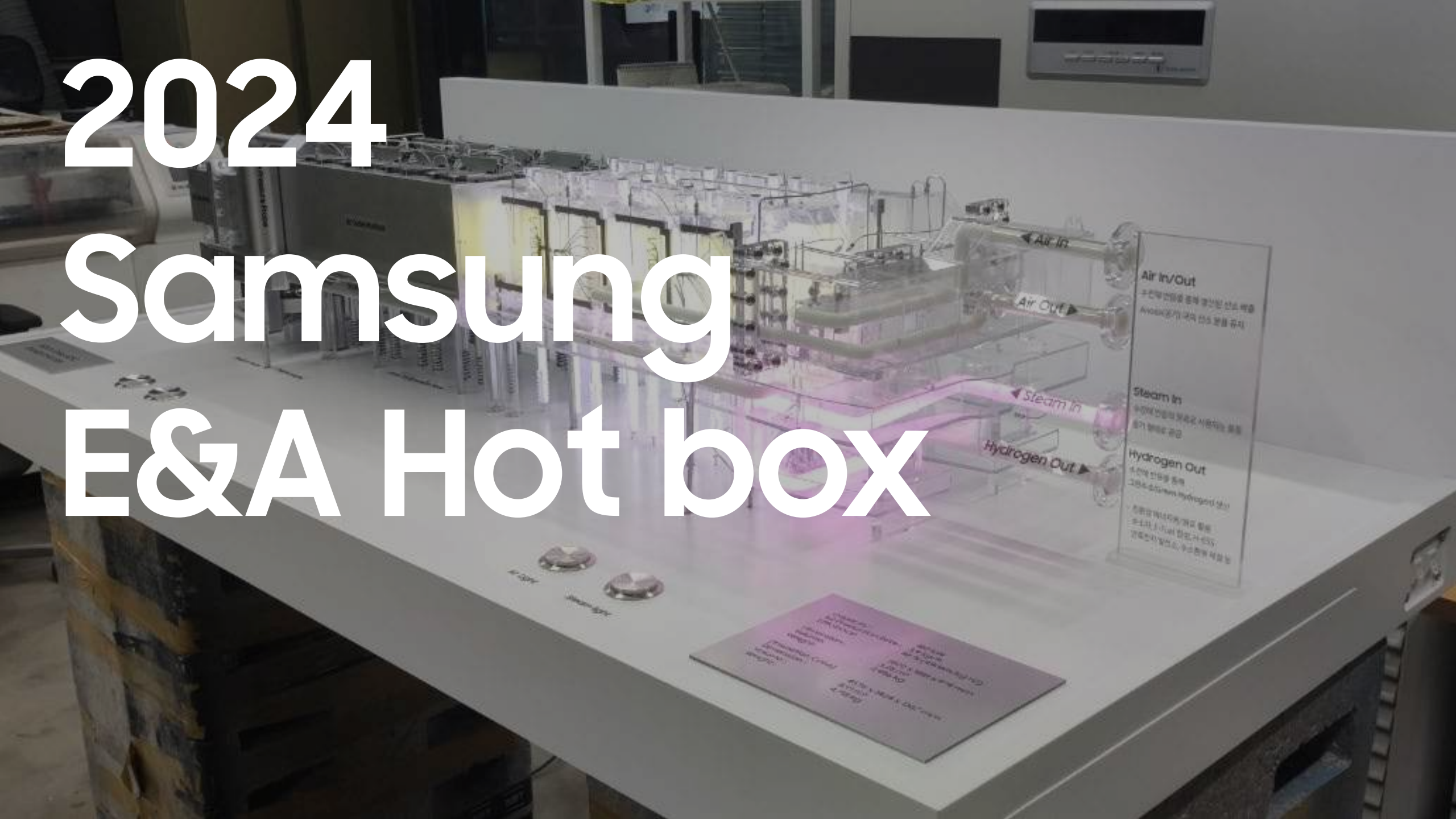

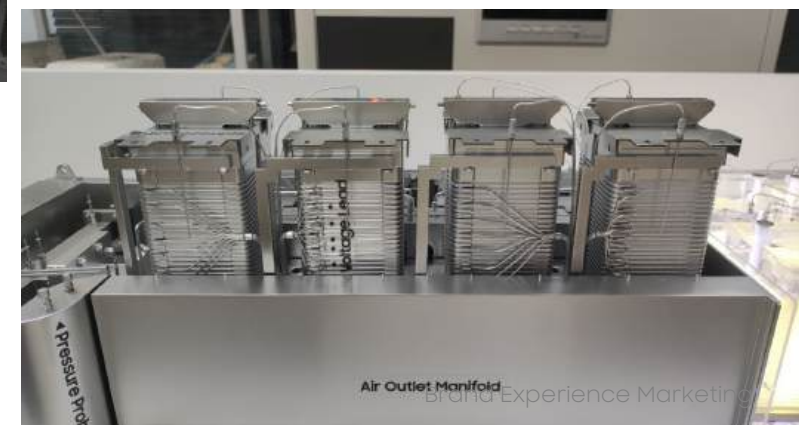
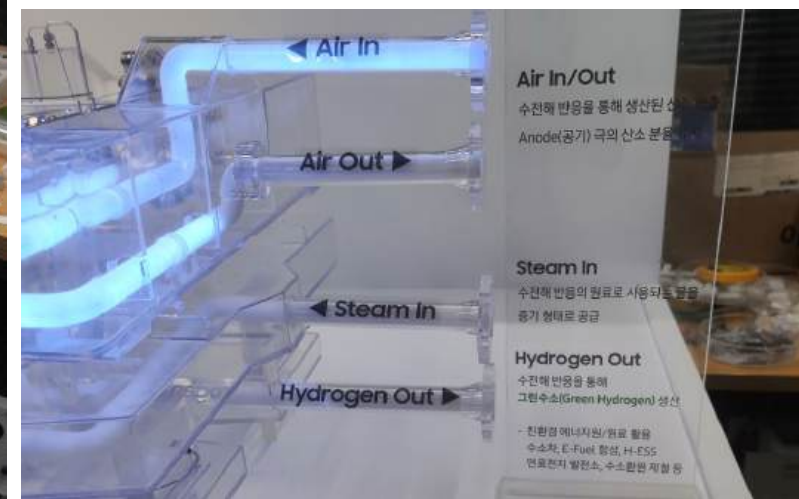
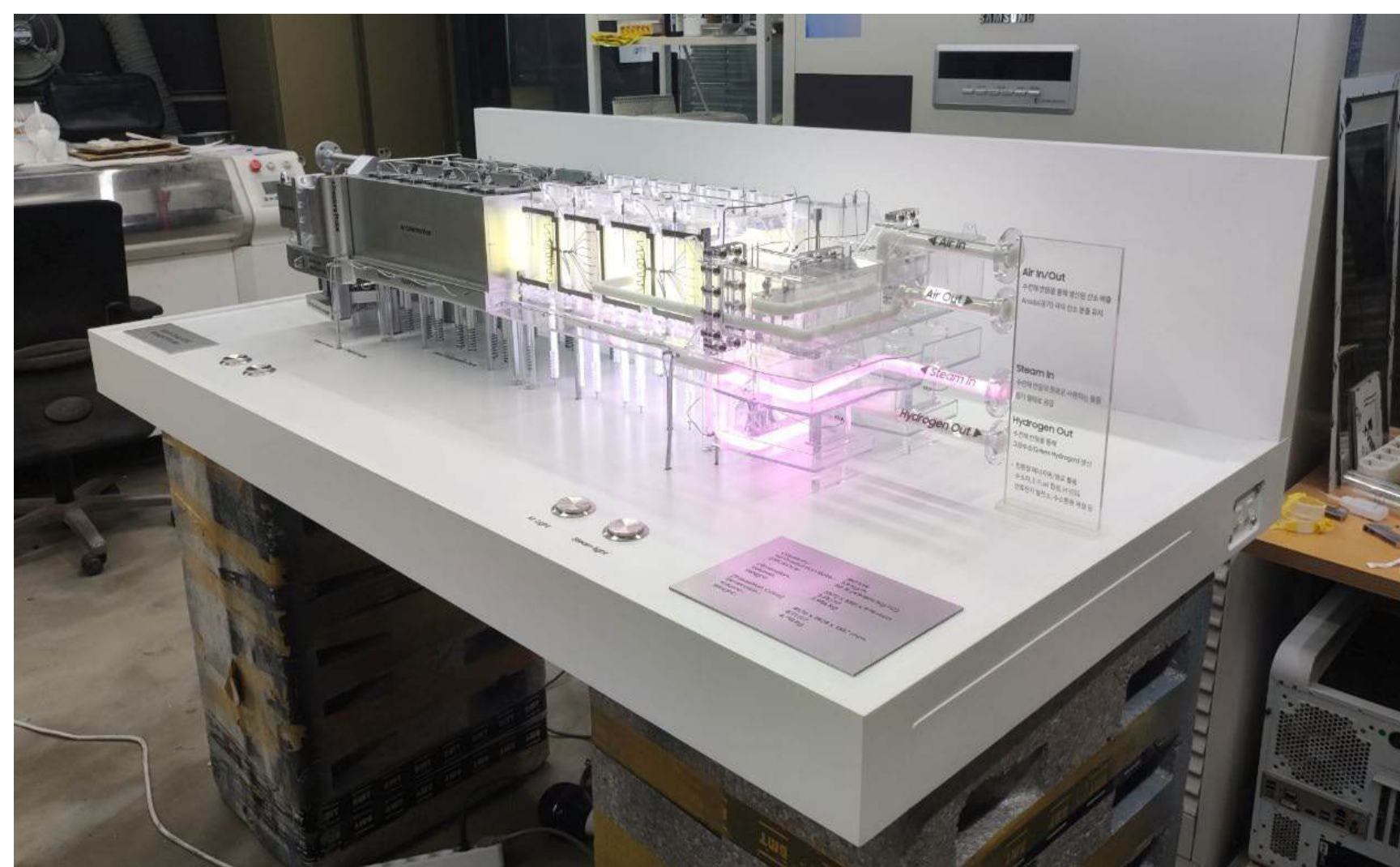

Models 2024  
development for  
Samsung E&A Hot box

# 2024 Hyundai Brand Goods Shop

The image shows the interior of a retail store. The space is bright and modern, with white walls and a light-colored floor. On the left, there are white shelves displaying various items, including books and small figurines. In the center, a large, low-profile counter holds a display of colorful toys and a blue sports jersey. To the right, another counter is visible, and a tall, narrow shelving unit holds a green mug and other items. The ceiling is equipped with track lighting, and a green LED light strip runs along the top of the wall on the left. The overall aesthetic is clean and organized.



**Experience & Space  
development for Hyundai  
Brand Goods Shop 2024**

2024

GENESIS CMF

Cheongju





**Models 2024**  
**GENESIS CMF in Cheongju**

# Inter Battery Europe 2024 Samsung SDI

Chiller

Intake Damper

Advanced Fire Safety Design  
ALPHA Fire Safety (www.alphafire.com)

Canada

526

Lithium-Ion Battery



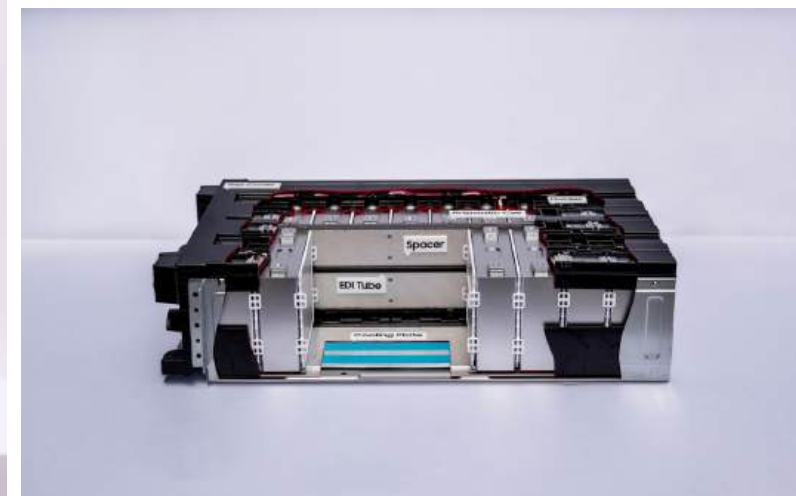
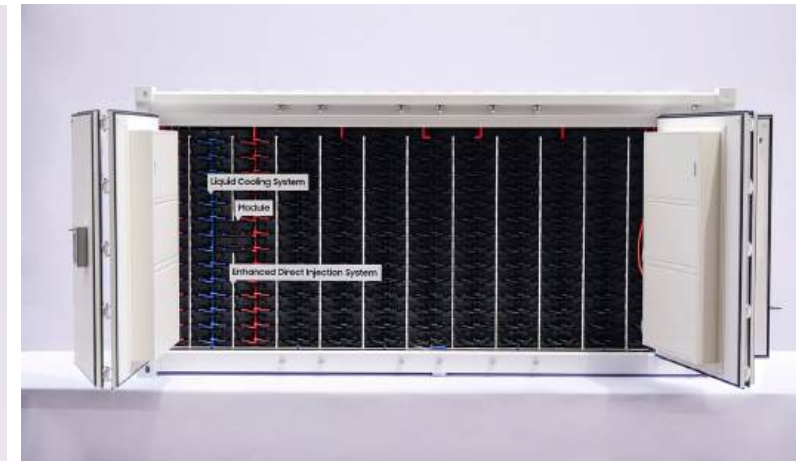
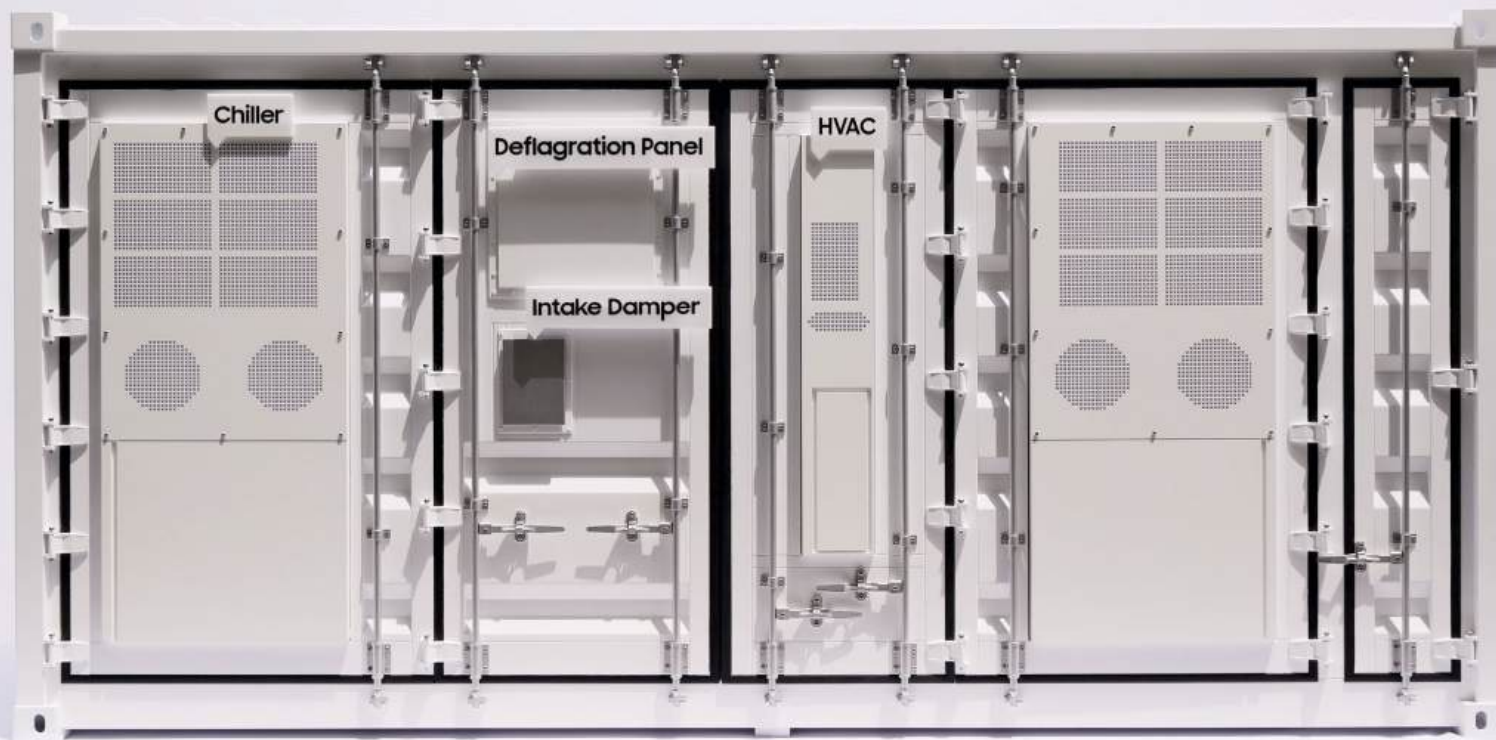

Models  
development for Samsung SDI  
InterBattery Europe 2024 in Munich, Germany

2024 Paris

Olympic™

Rendezvous

Samsung Showcase

SAMSUNG

Galaxy

XU JY0LC



**Experience & Space  
development for Samsung  
2024 Paris Olympic™**

# AWE 2024 Samsung





Exhibition zone development for Samsung AWE 2024 in Shanghai, China

# Samsung Networks MWC 2024

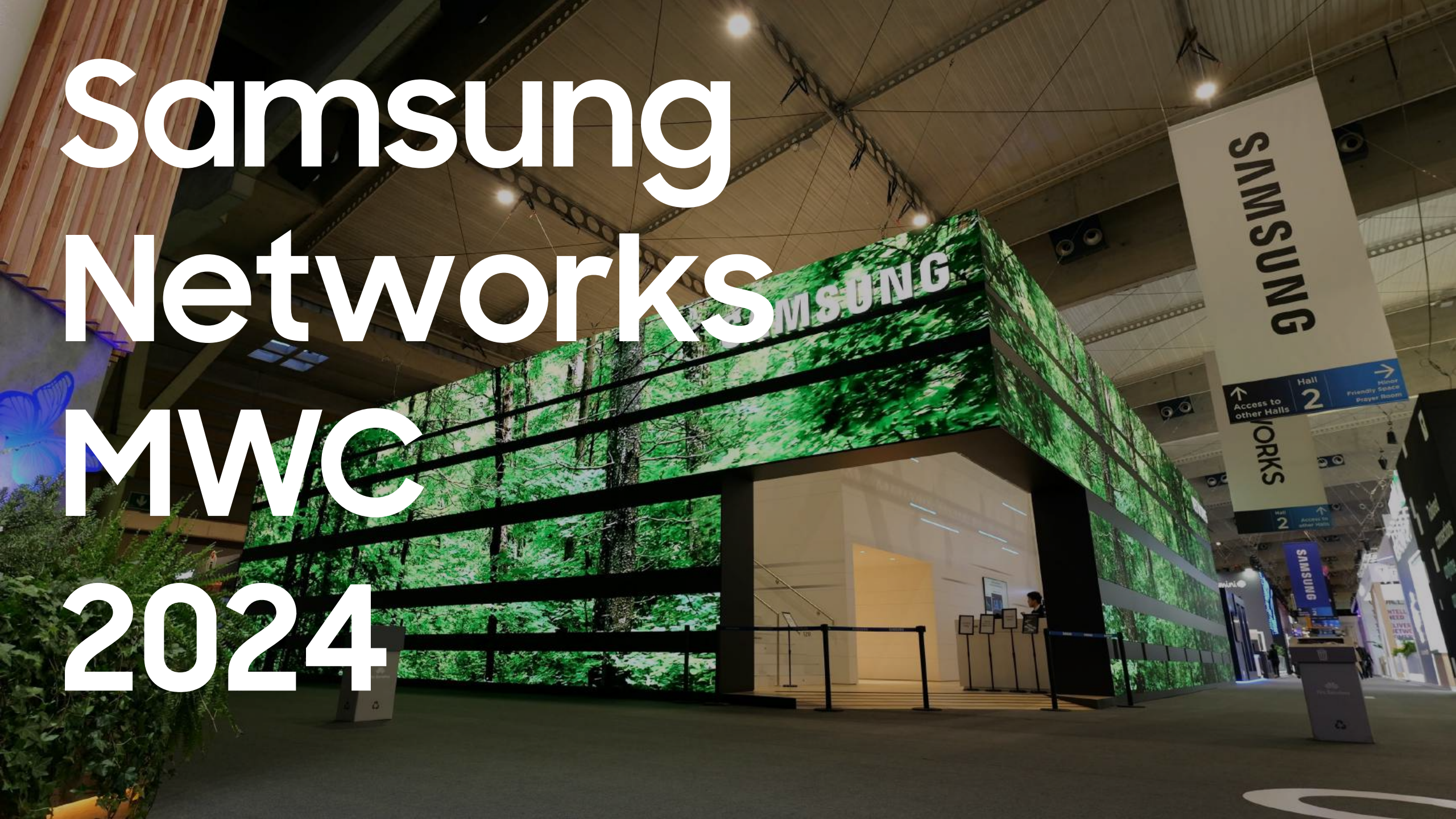

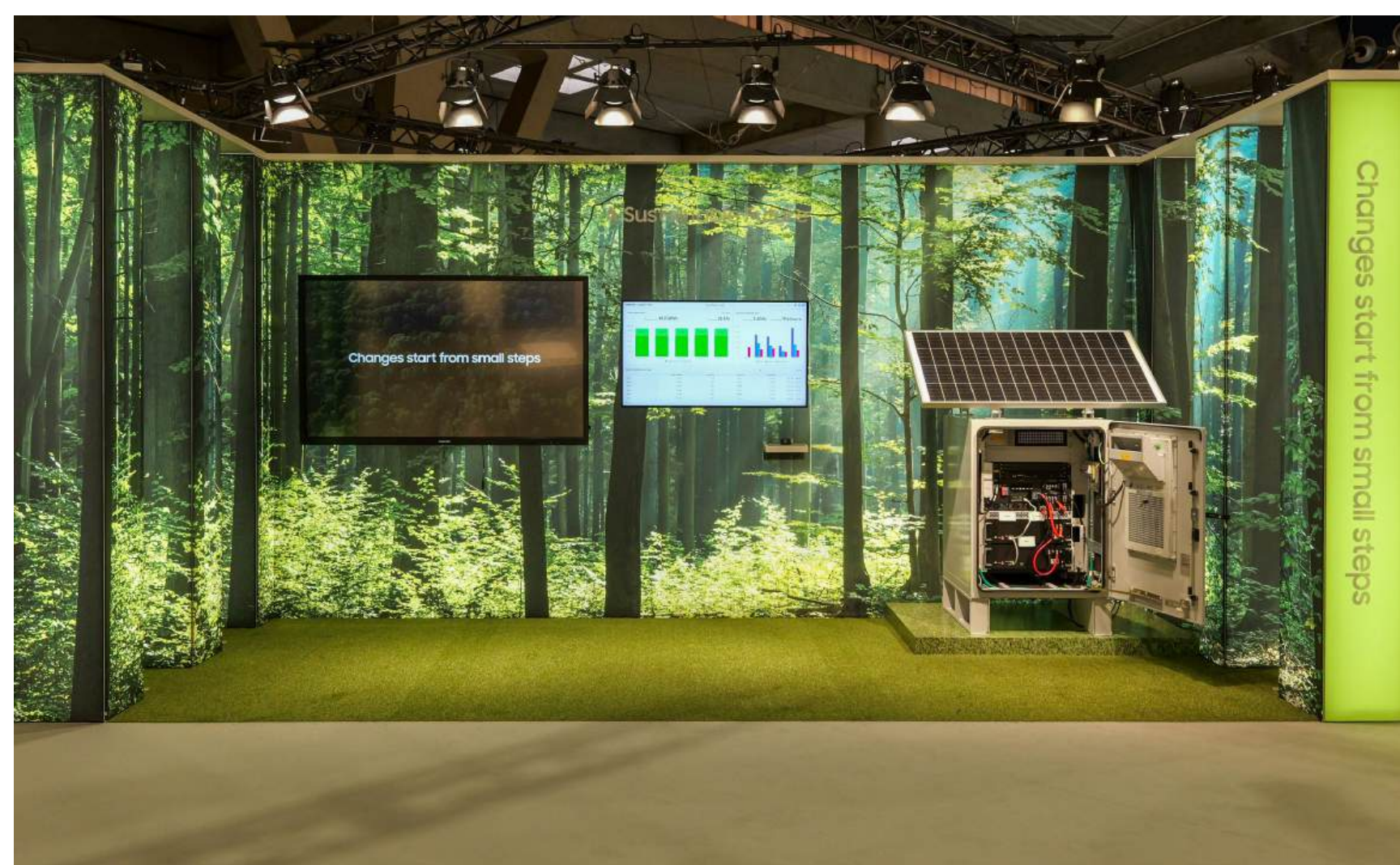

Key Visual & Models & System development for Samsung Networks MWC 2024 in Barcelona, Spain



# JUNG KWAN JANG Off-line Store JeongMall





Experience & Space  
development for JUNG KWAN JANG  
Off-line Store 正 Mall in Seoul, Korea



# Samsung Biologics Vision Showroom





Showroom  
development for Samsung Biologics  
Vison Showroom in Incheon, Korea

# CES 2024

# XREAL



air<sup>2</sup> ultra

XREAL

XREAL

XREAL

LET'S GO SPATIAL NOW

LET'S GO SPATIAL NOW

LET'S GO SPATIAL NOW

COSM

Etron

Etron

MemoraLink

DeChick

MEMORA LINK

DECHICK

MEMORA LINK

DECHICK

MEMORA LINK

DECHICK

MEMORA LINK

DECHICK

MEMORA LINK

DECHICK

MEMORA LINK

DECHICK

MEMORA LINK

DECHICK

MEMORA LINK

DECHICK

MEMORA LINK

DECHICK

MEMORA LINK

DECHICK

MEMORA LINK

DECHICK

MEMORA LINK

DECHICK

MEMORA LINK

DECHICK

MEMORA LINK

DECHICK

MEMORA LINK

DECHICK

MEMORA LINK

DECHICK

MEMORA LINK

DECHICK

MEMORA LINK

DECHICK

MEMORA LINK

DECHICK

MEMORA LINK

DECHICK

MEMORA LINK

DECHICK

MEMORA LINK

DECHICK

MEMORA LINK

DECHICK

MEMORA LINK

DECHICK

MEMORA LINK

DECHICK



Space design  
development for Xreal  
CES 2024 in Las Vegas, USA

# HD HYUNDAI CES 2024

Xite Transformation

nsformation



DEVELON | HYUNDAI

Powered by Innovation® | Comfort Intelligence™

Technical specifications and diagrams are visible on the stage floor.



Key Visual & Models  
development for HD HYUNDAI  
CES 2024 in Las Vegas, USA

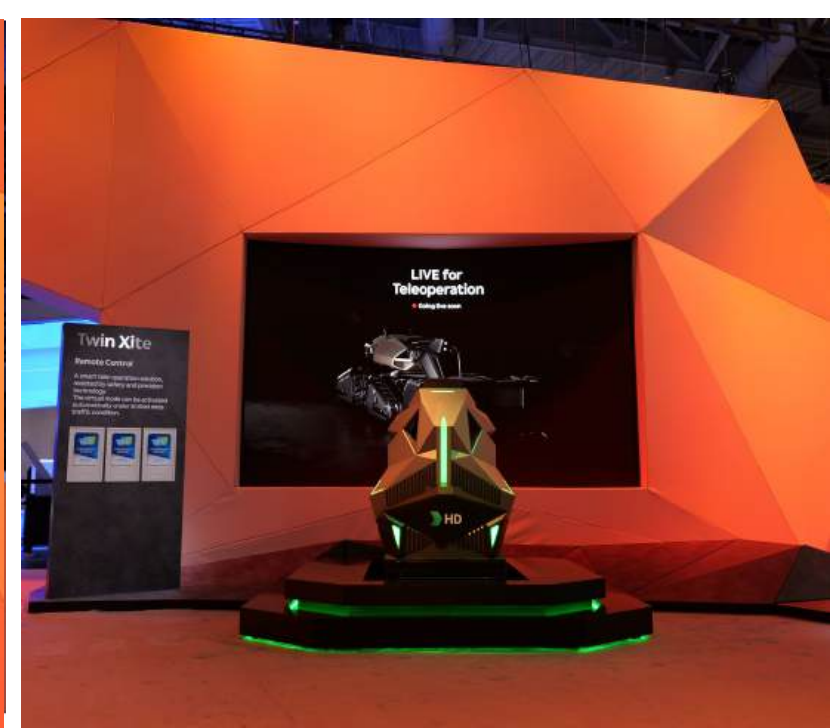
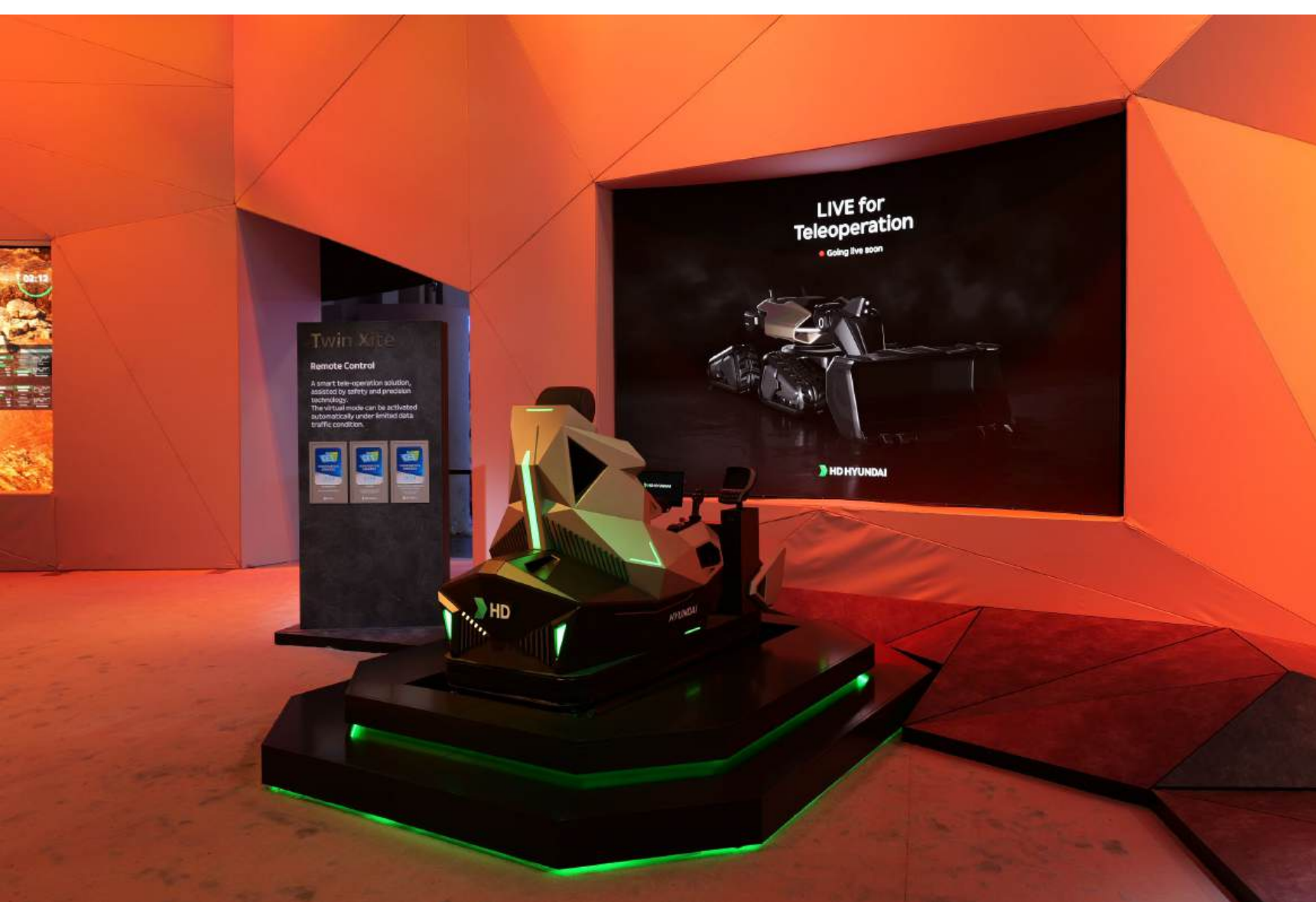

**Key Visual & Models  
development for HD HYUNDAI  
CES 2024 in Las Vegas, USA**

# MEPTANG

# GO 2023





## Samyang Meptang Food Truck Event Promotion Development In Korea





## Samyang Meptang Food Truck Event Promotion Development In Korea



# Diablo 4 Launching Campaign 2023





**Diablo 4 Hell station  
Experience zone Development  
In Yeongdeungpo Market Station**









## Diablo 4 Pop-up Store Experience zone Development In THE HYUNDAE SEOUL



# SAMSUNG

					
BESPOKE Refrigerator	Galaxy Z Fold5   Z Flip5	The Freestyle 2 <sup>nd</sup> Gen.	BESPOKE Jet™ AI	Galaxy Tab S9   Watch6	Odyssey Neo G9

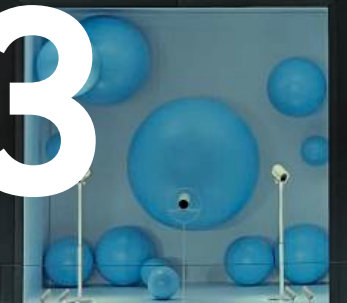
# IFA 2023 SAMSUNG

				
The Wall	The Wall	The Wall	The Wall	The Wall



## Key Visual & Models development for Samsung IFA 2023 in Berlin, Germany



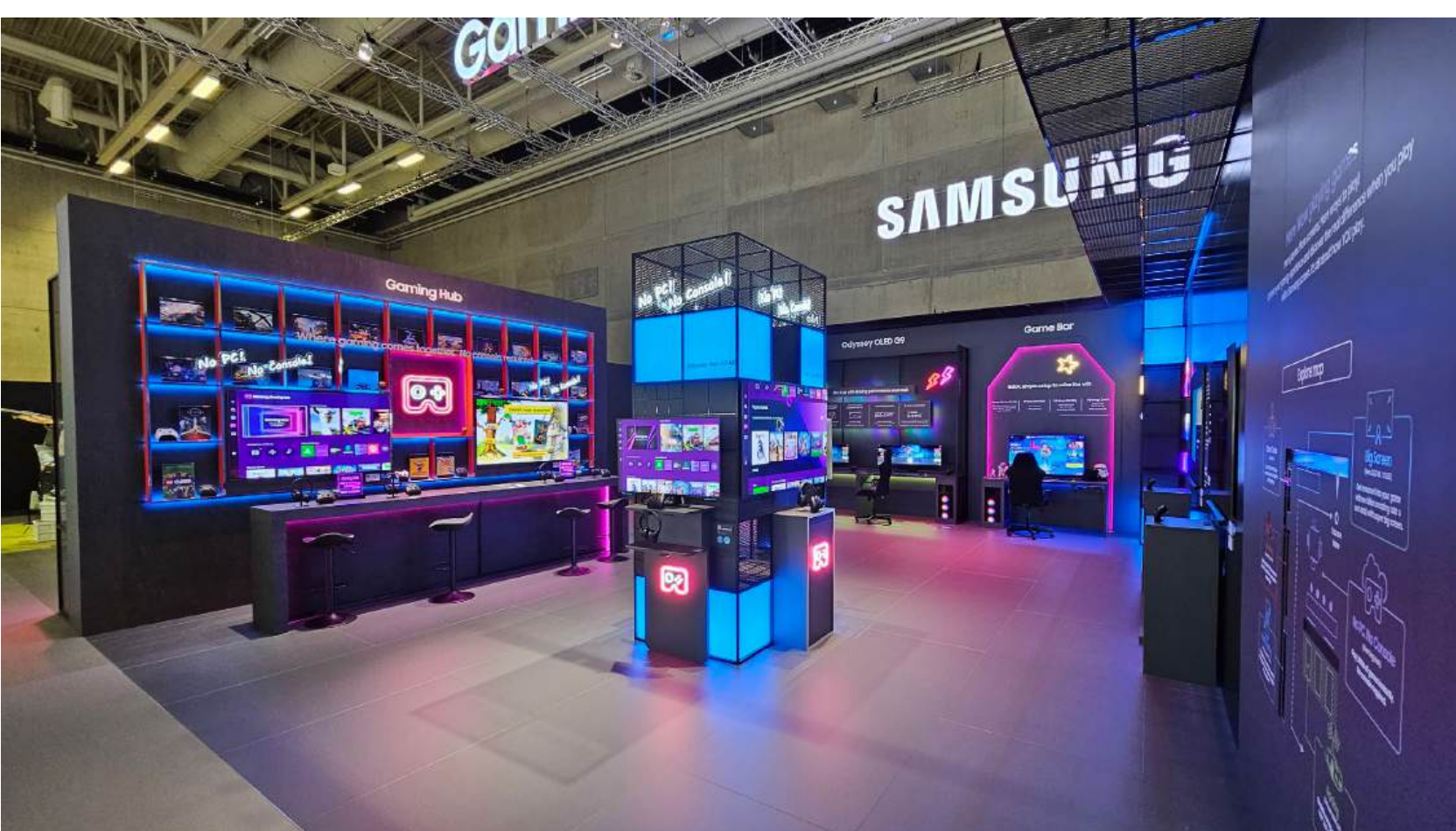

## Key Visual & Models development for Samsung IFA 2023 in Berlin, Germany









**Deriving a design that expresses the traditional beauty of Korea**

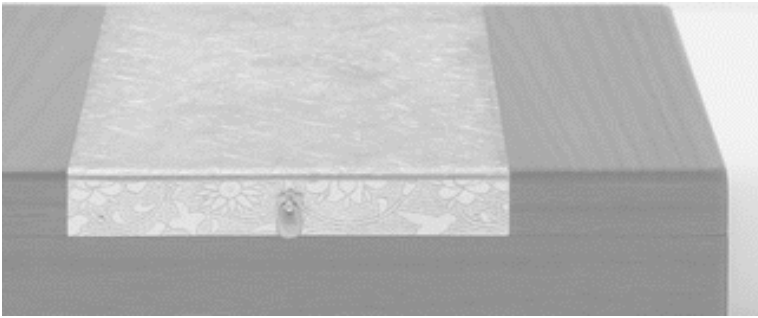

Develop CMF Experience Trunk Design for Games

**12.1/CMF Trunk Design**

**Design A. Kings Man**

W 114 x H 8 x D 33

Develop CMF Experience Trunk Design for Games

**12.1/CMF Trunk Design**

**Materials**

Class Design

Material: P 122 x W 125 x D 41

Check for the correspondence of colors and volumes of volume material

Change to P 124 x W 125

Check for the correspondence of colors and volumes of volume material

Develop CMF Experience Trunk Design for Games

**12.1/CMF Trunk Design**

**Scenario**

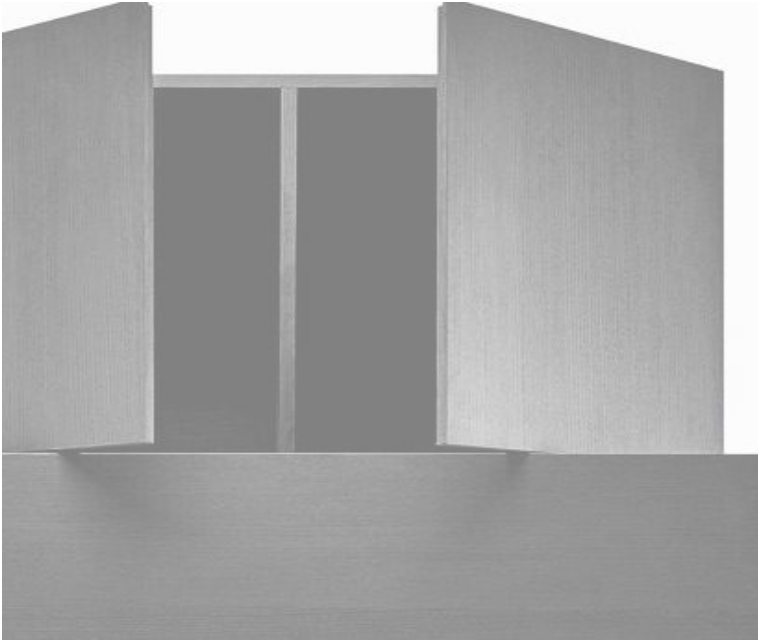

Develop CMF Experience Trunk Design for Games

**12.2/CMF Trunk Design**

**Design B. Mono Trunk**

W 114 x H 8 x D 33

Develop CMF Experience Trunk Design for Games

**12.1/CMF Trunk Design**

**Stand Type**

Develop CMF Experience Trunk Design for Games

**12.2/CMF Trunk Design**

**Scenario**



Develop CMF Experience Trunk Design for Games

**12.4/CMF Trunk Design**

Develop CMF Experience Trunk Design for Games

**12.4/CMF Trunk Design**

Develop CMF Experience Trunk Design for Games

**12.4/CMF Trunk Design**

**Scenario**



**2023 GENESIS**  
**Mobile CMF**  
**Mass-production**





**2023 GENESIS**  
**Fixture CMF**  
**Mass-production**



# Samsung Networks MWC 2023





## Key Visual & Models development for Samsung Networks MWC 2023 in Barcelona, Spain



# 2023 Galaxy 23 Experience zone



**2023 Galaxy 23  
Experience zone  
Development  
for Galaxy Studio experience kit  
In Seongsu, Korea**



**2023 Galaxy 23  
Experience zone  
Development  
for Galaxy Studio experience kit  
In Hongdae, Korea**



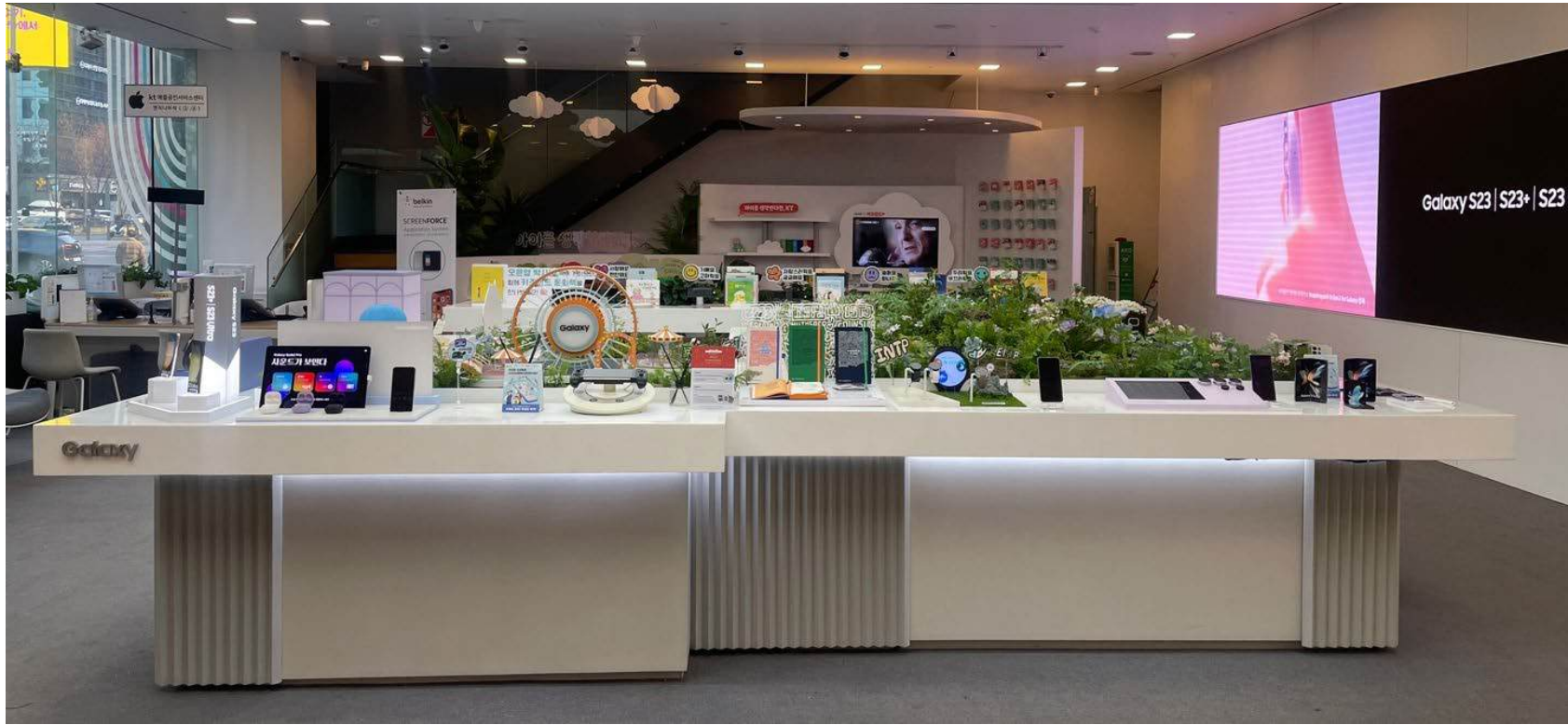

**2023 Galaxy 23  
Experience zone  
Development  
for Galaxy Studio experience kit  
In Gangnam, Korea**



# Samsung GMC

# CES 2023

How easier  
to never

Pair your new appliances with SmartThings simply by plugging it in, or by tapping the notification on your phone. Getting the devices reconnected after a move or a router change is a breeze.



SmartThings

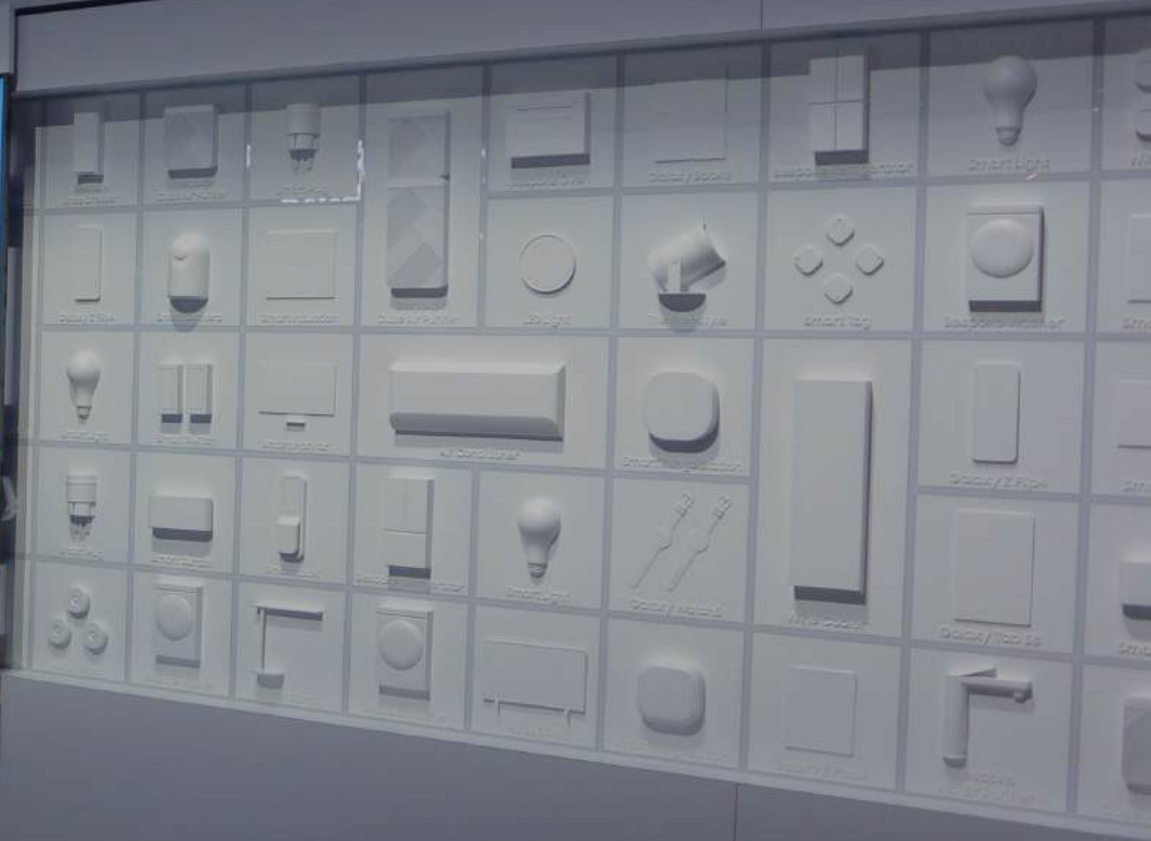



## Key Visual & Models development for Samsung GMC CES 2023 in Las Vegas, USA

# LG Labs MONSHOECL CES 2023



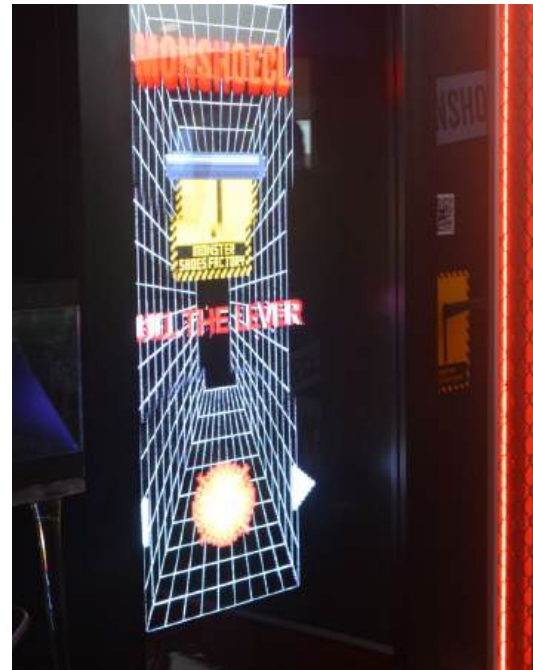

## Key Visual & Models development for LG Labs CES 2023 in Las Vegas, USA

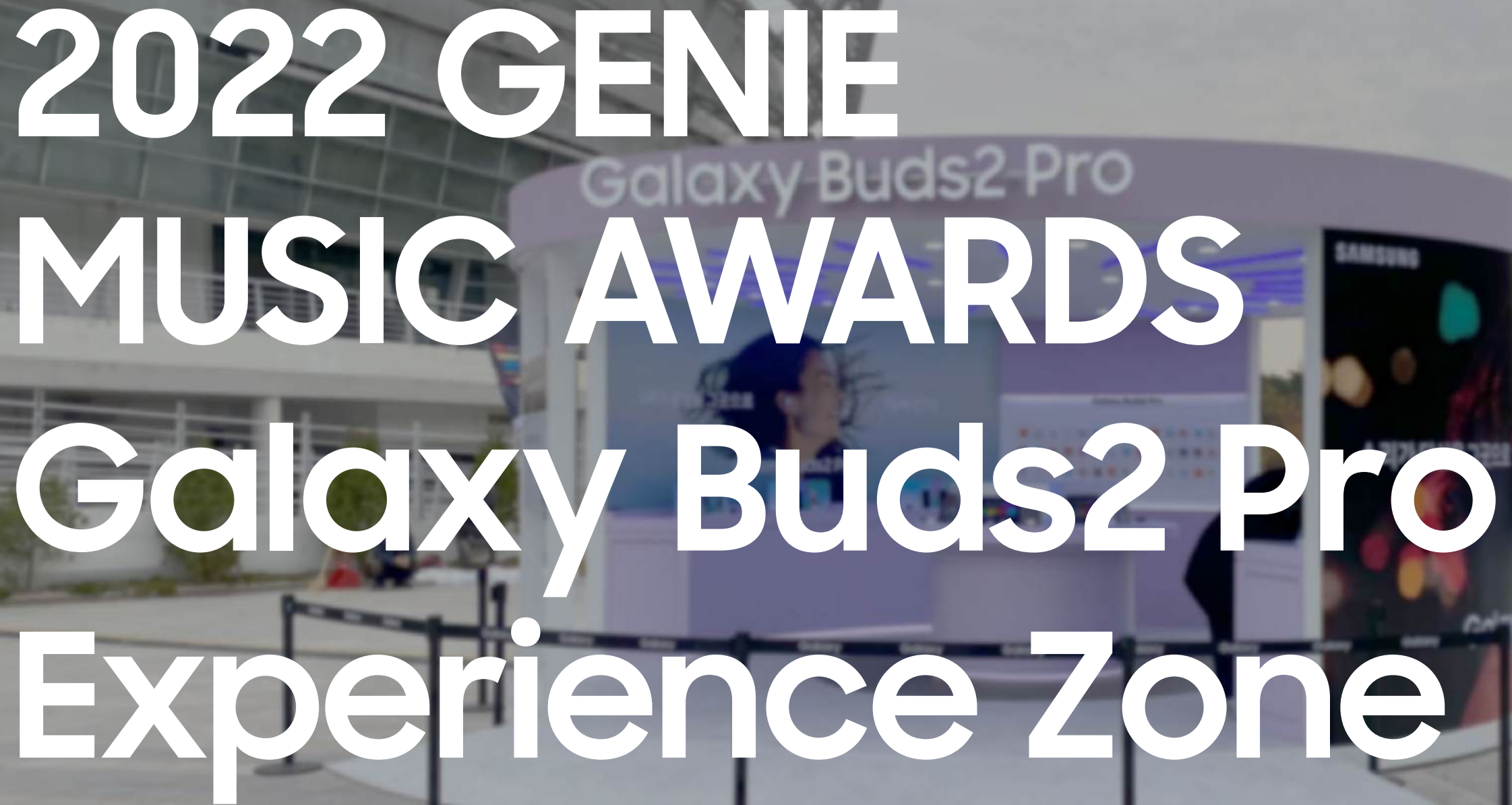

# 2022 GENIE MUSIC AWARDS Galaxy Buds2 Pro Experience Zone



**2022 GENIE MUSIC AWARDS  
Galaxy Buds2 Pro Experience zone  
Development for experience kit**



# 2022 Galaxy Z Fold 4 / Z Flip 4 Experience zone

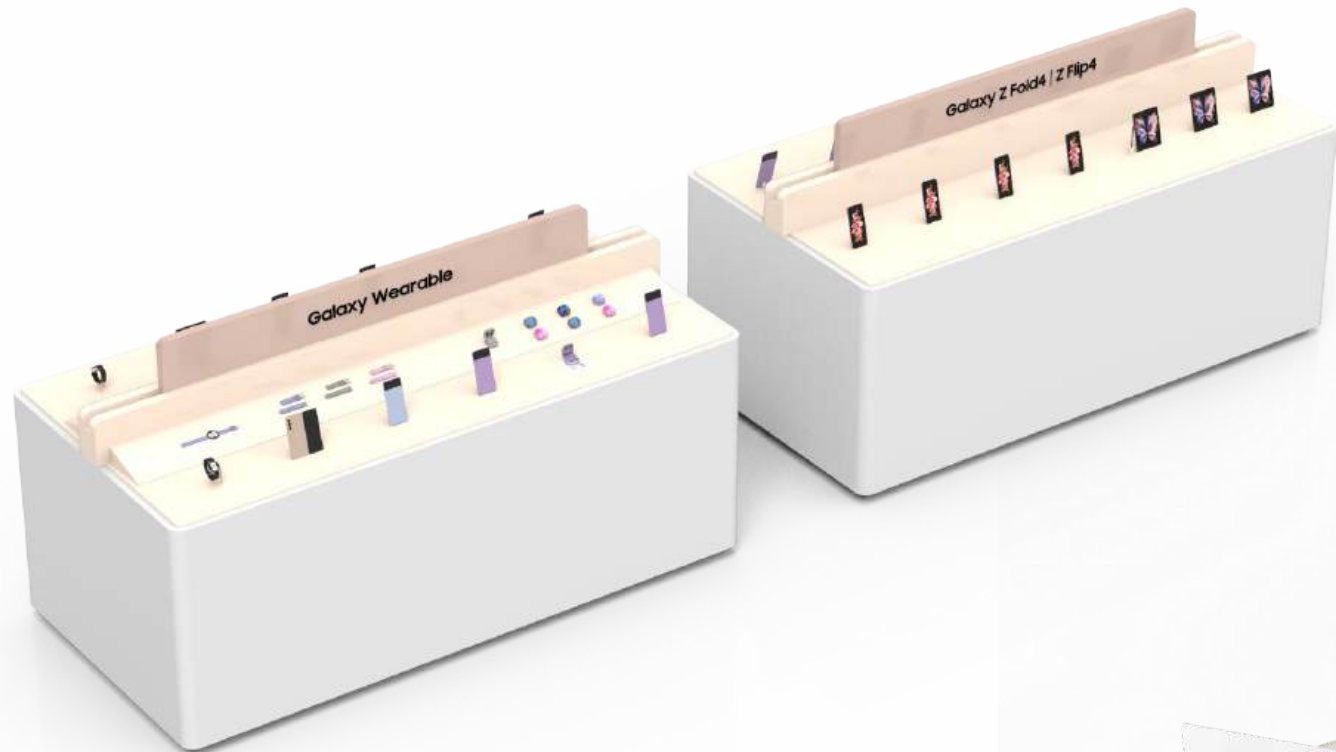

**2022 Galaxy Z Fold 4 / Z Flip 4  
Experience zone  
Development  
for Galaxy Studio experience kit**

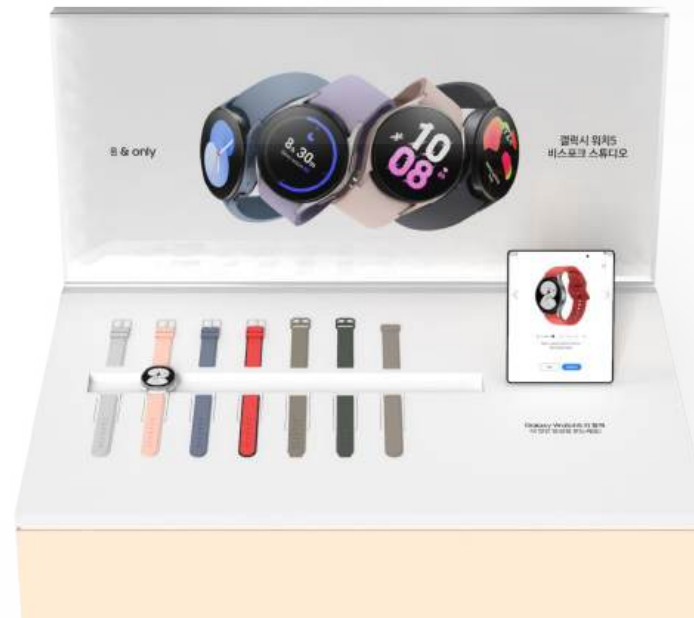

2022 Galaxy Z Fold 4 / Z Flip 4  
Experience zone  
Development  
for Galaxy Studio experience kit



**2022 Galaxy Z Fold 4 / Z Flip 4  
Experience zone  
Development  
for Galaxy Studio experience kit**





**2022 Galaxy Z Fold 4 / Z Flip 4  
Experience zone  
Development  
for Galaxy Studio experience kit**

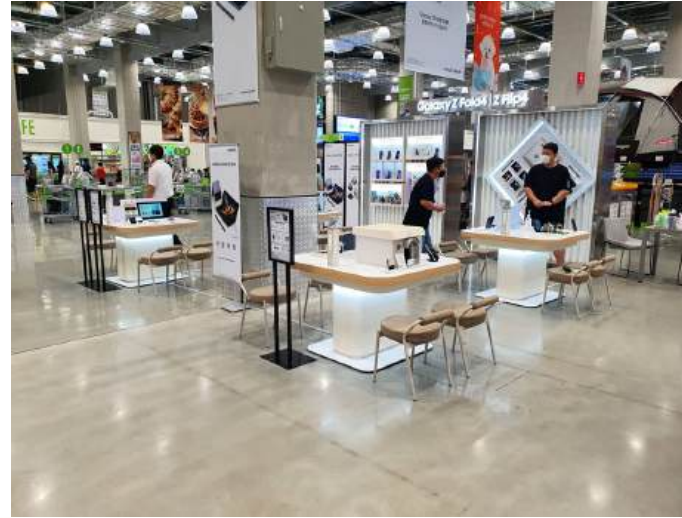

# Kidzania Museum Experience



AUTOMOBILE CENTER

CAR DESIGN STUDIO  
카 디자인 스튜디오

DRIVING TRACK  
드라이빙 트랙



Mercedes-Benz Center  
카 디자인 스튜디오  
드라이빙 트랙





Car Model development for Kidzania Museum Experience



**Car Model development for  
Kidzania  
Museum Experience**



**Car Model development for  
Kidzania  
Museum Experience**



**KES 2022**

**Samsung Eco Tree  
Lighting Experience**



## KES 2022 Samsung Eco Tree Lighting Experience zone Development

# 2022 Samsung ECO Package Campaign



**Samsung ECO Package  
Campaign 2022  
Experience zone Development  
In IFC Mall**





**Samsung  
BIOLOGICS**

**BIO International  
Convention 2022**

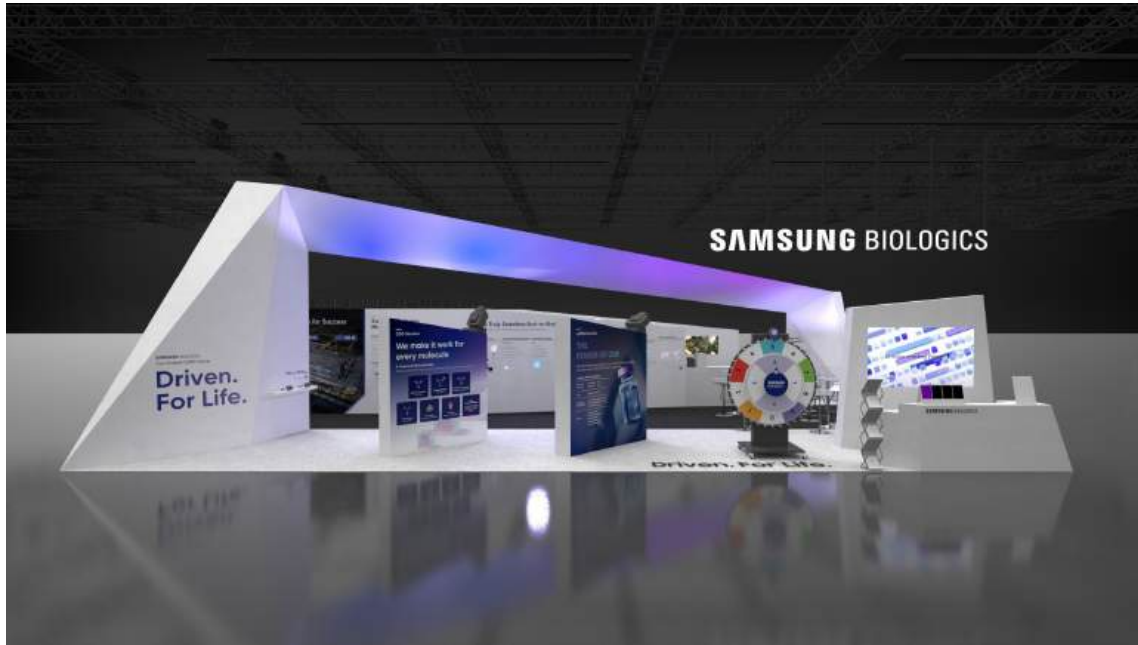

## 2022 Samsung Biologics BIO International Convention Booth Design in San Diego, USA

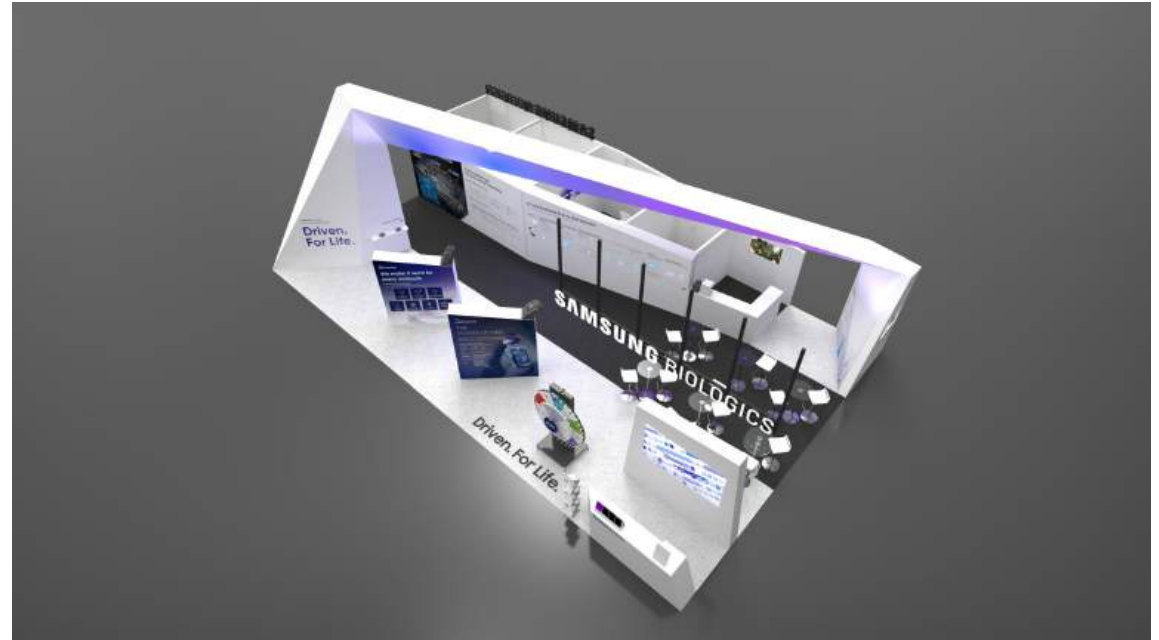

# 2022 Beijing Olympic Showcase

A blurred background image of a busy city street. In the center, there is a Samsung store with the word 'SAMSUNG' visible above the entrance. The street is filled with many pedestrians walking in various directions. The overall scene is a vibrant urban environment.



**2022 Beijing Olympic Showcase  
development for Samsung  
Galaxy Exhibition in Solana**





## 2022 Beijing Olympic Showcase development for Samsung Galaxy Exhibition in Sanlitun





## 2022 Beijing Olympic Showcase development for Samsung Galaxy Exhibition in Paradise



A blurred background image of a Samsung exhibition booth at CES 2022. The scene is dimly lit with blue and red ambient lighting. In the foreground, a curved display wall shows a vibrant red and pink abstract pattern. A person in a dark suit stands near the wall. In the background, several other people in business attire are engaged in conversations near other display areas.

# Samsung DS CES 2022



Samsung CXL Memory Expander

Server

Memory Solutions

PCIe 5.0 NVMe SSD PM1743

DDR5 RDIMM



## Key Visual & Models Development for Samsung CES 2022 Exhibition

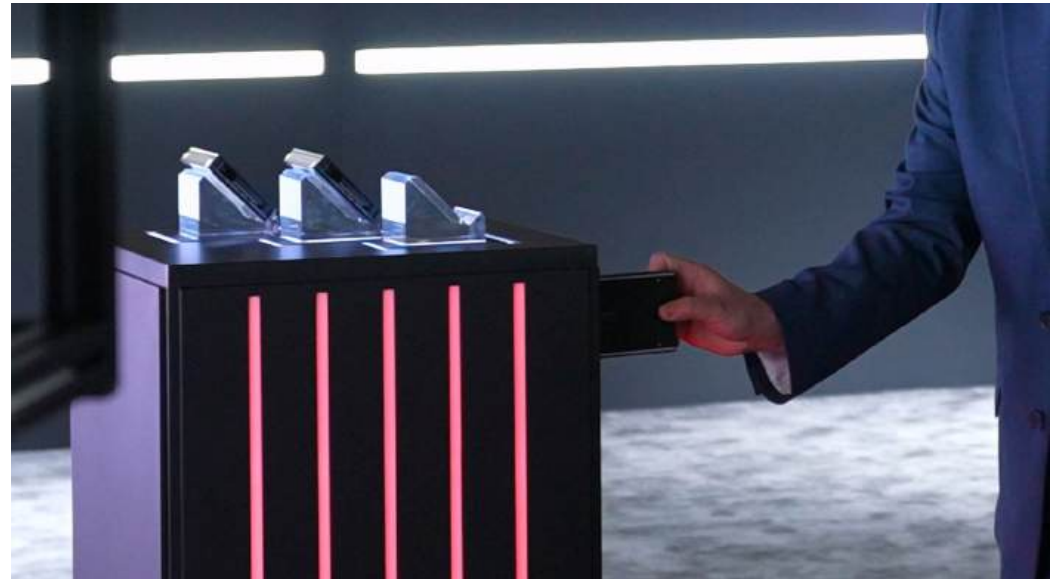

# Samsung VD CES 2022





# Samsung ESG ZONE – Going green Development for Samsung CES 2022 VD Exhibition



## The freestyle Development for Samsung VD CES 2022 Exhibition



# Hankooktire TNDL Project

A futuristic, dark-colored car model is displayed on a white circular base with a glowing blue light ring. The car is positioned in a modern office environment with large glass windows in the background. Another similar car model is visible in the distance on a white pedestal.



## Models development for Hankooktire TNDL Project



# SAMSUNG DS SEDEX 2021

A photograph of a Samsung exhibition booth at the SEDEX 2021 event. The booth features a prominent blue and green color scheme. A large blue banner at the top displays the Samsung logo. The booth is equipped with various displays, including a large screen on the left and a wall of smaller screens on the right. The text 'SAMSUNG' is visible on the top banner, and 'Technology & Humanity Empowering the World' is displayed on a black wall to the right.

Technology & Humanity  
Empowering the World



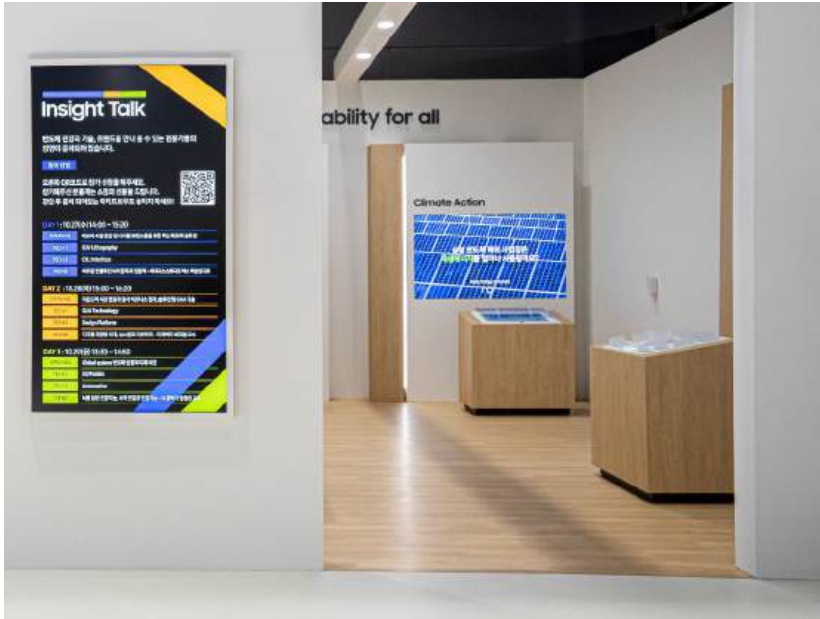

# Key Visual & Models development for Samsung SEDEX 2021 Exhibition

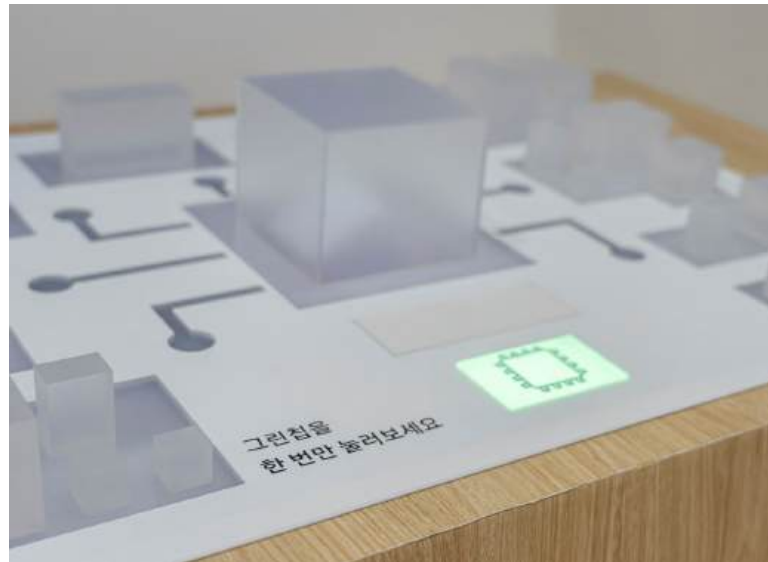



# 2020 Galaxy Studio Ex. Kit & Wearable Table





가슴이 텅빈것이, 너도 아픈 사랑을 했구나

이진호

가슴이 텅빈것이

이진호

말레니얼 작가들이 5편으로 남긴  
글과 그림이 말살의 오브제에 담겨  
힐링이 되는 새로운 작품으로 탄생했습니다

2022 CANDIES





노트20로  
QLED 8K로

비밀배출 사도  
앞서  
줄 맞춰 도입

무선으로 자유로



## Models development for Samsung experience zone for Galaxy Note S20





## Models development for Samsung experience zone for Galaxy Note S20



# 2020 CES VD HL Zone

QLED 8K



# QLED 8K



Turn what you love into 8K

4K



8K



## 20 QLED 8K AI Upscaling

Quantum processor 8K now provides deep learning based 8K AI Upscaling. Its algorithms created by deep learning from over 10 million data sets adjust themselves real-time according to content types and restore details of each scene to true-to-life 8K quality.



Artificial neural networks that adjust algorithms real-time according to characteristics of content and regions.

## Quantum AI

Samsung QLED's deep learning based Quantum Processor combined with Tizen, the world's smartest TV platform, opens up endless possibilities with AI. We call it Quantum AI. In 2020, Samsung brings to you home incredible innovations in picture, sound, user experience and more with Quantum AI.

Picture  
Provides perfect picture quality with deep learning algorithms adjusting the content for your watching spot in an environment where you're watching.



### AI Smart

Intelligently content while also recommending better experience for the user.

### AI Sound

Provides perfect immersion with an optimized sound experience by recognizing the movement of objects in the content and analyzing noises in the space where content is being viewed.

Turn what you love into 8K

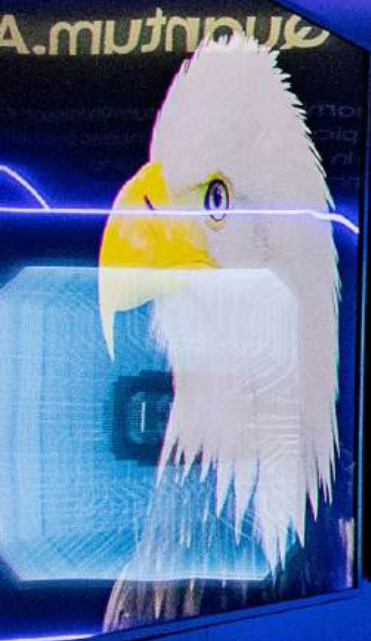

# Quantum.AI

Samsung QLED's deep learning based Quantum Processor combined with Tizen, the world's smartest TV platform, opens up endless possibilities with AI. We call this Quantum.AI. In 2020, Samsung brings to your homes incredible innovations in picture, sound, user experience and IoT with Quantum.AI.

## AI Picture

Provides the best 8K picture quality with deep learning by constantly analyzing the content that you're watching and the environment where you're watching them.

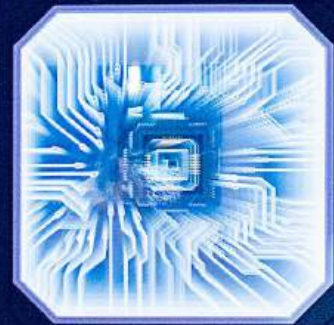

## AI Smart

Enables daily content views, device usage, and voice commands, while also connecting and recommending for the best experience for the Big Screen.

## AI Sound

Provides perfect immersion with an optimized sound experience by recognizing the movement of objects in the content and analyzing the noises in the space where the content is being viewed.

Room



check your mobile all on the big screen



# QLED 8K

Variety of 8K screens in all sizes

## 55"

Samsung Electronics, the world's No. 1 TV maker for 13 consecutive years.







# IFA 2019

## VD HL Zone

### Super Big TV

98" 75" 55"

# 2019 IFA VD Lifestyle Zone

**DATE** 6 Sept 2019 - 11 Sept 2019 (6 Days)  
**HOUR** 10:00 - 18:00  
**VENUE** Messe Berlin, Germany  
**STATISTICS** Approx. 1,805 Exhibitor 158K Visitor (2018)  
**TARGET** Customers & Visitors  
**ITEM** Big Screen, Sound Bar

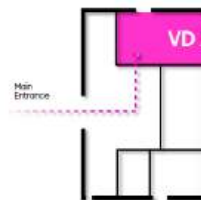

## Overview

01  
Scope of Work #1  
Hero Product

## Big Screen

Bigger is better anywhere

Design Structure: As is > To be



Within the IFA VD Zone,  
Experience the super-sized screen to visitors.  
When you come into life, you'll see more and more experience.  
It gives you experience.

Provide space and experience design to benefit from the product.

### Intelligent Upscaling

Samsung makes it possible to enjoy viewing on a Big Screen TV without eye fatigue or discomfort. Thanks to Samsung's unique 5-step intelligent upscaling technology, any distance is a safe viewing distance with a Big Screen TV. The Samsung intelligent engine analyzes each scene to produce optimal colour, contrast, and 4K detail.

### Game Mode

Samsung provides the optimal environment for uninterrupted, immersive gaming on a Big Screen TV. Maximize your gaming experience with advanced features like lower input lag, variable refresh rate (VRR) and Game Motion Plus, for a fluid and fast-paced field of view. You can also switch over automatically from TV to game mode with Auto Game Mode.

### Ambient Mode

With Samsung, a Big Screen no longer equals super big. Transform your Samsung Big into a part of the surrounding. Display background artwork, useful information or your pet without the risk of high brightness. You can even set it to play 5 to enhance the mood of your

# 2019 IFA VD Zone Product Solution Design Proposal

17 JULY 2019

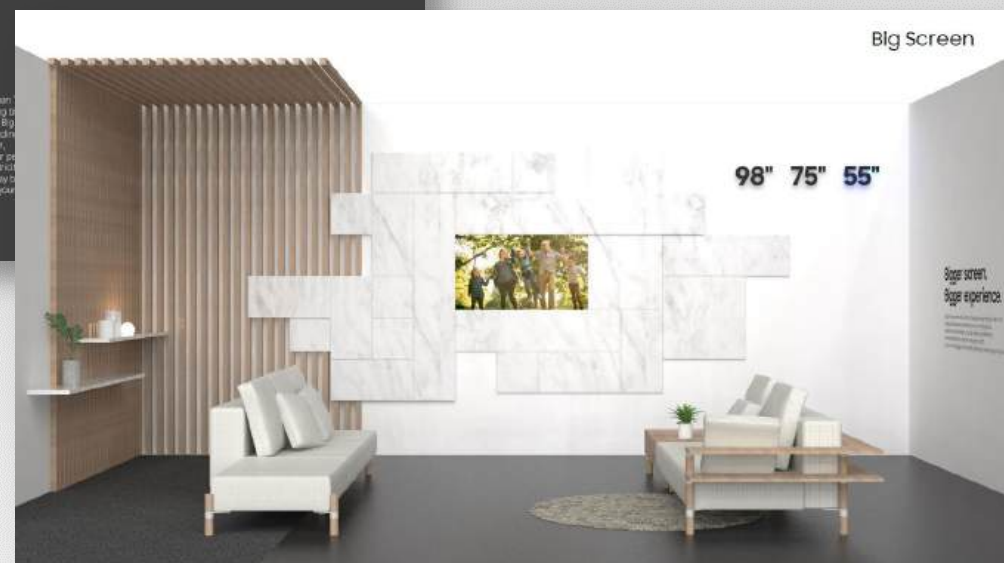

# SAMSUNG

## Super Big TV

QLED 75"+ is just right

**98"** **75"** **50"**

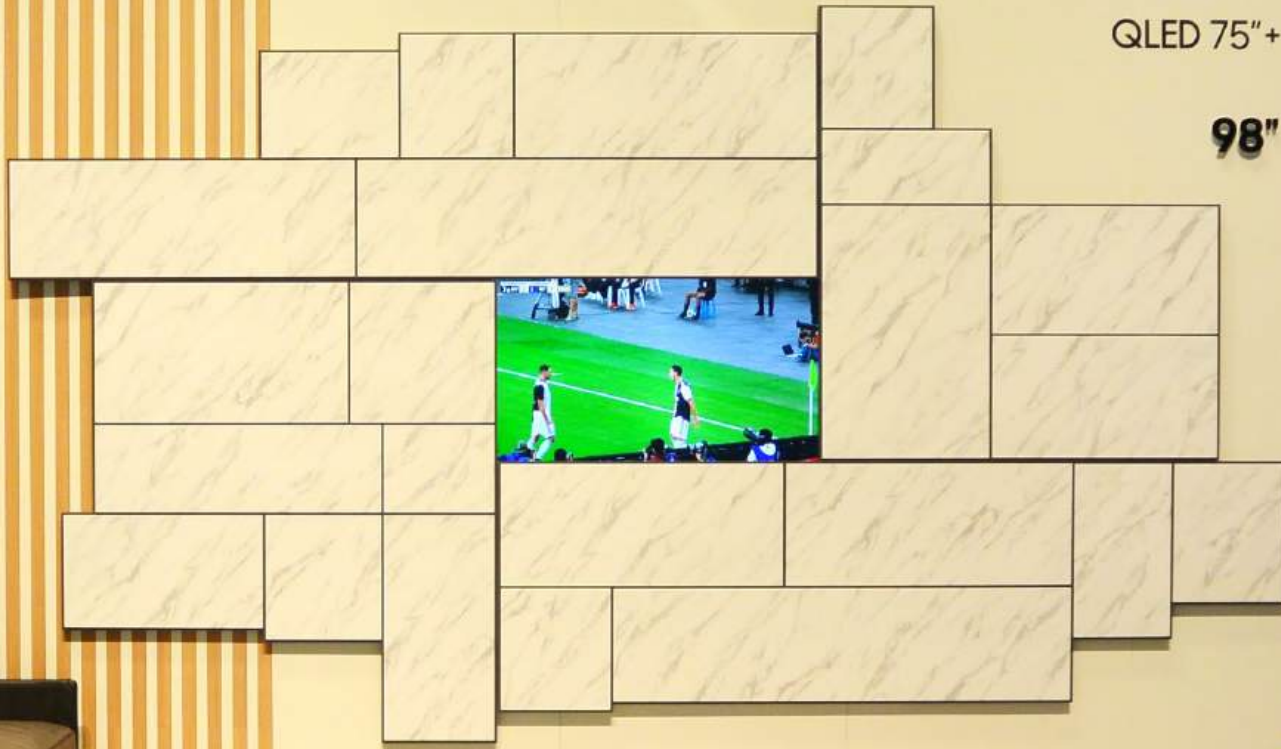

**8** out of 10 consumers made the switch to a bigger screen

**98%** of consumers who bought TVs of 75" or above said they are highly satisfied with their purchase.

© Samsung Electronics America, Inc. 2023



Discover Samsung

## Super Big TV

QLED 75"+ is just right

98" 75" 50"

8 out of 10 consumers made the switch to a bigger screen

98% of consumers who bought TVs of 75" or above are highly satisfied with their purchase



The background is a blurred photograph of an AV room. It features a large screen displaying a colorful abstract pattern, a sound bar mounted below it, and a smaller screen to the right. The text is overlaid on the left side of the image.

# IFA 2019

# VD HL Zone

# Sound Bar

# AV Room

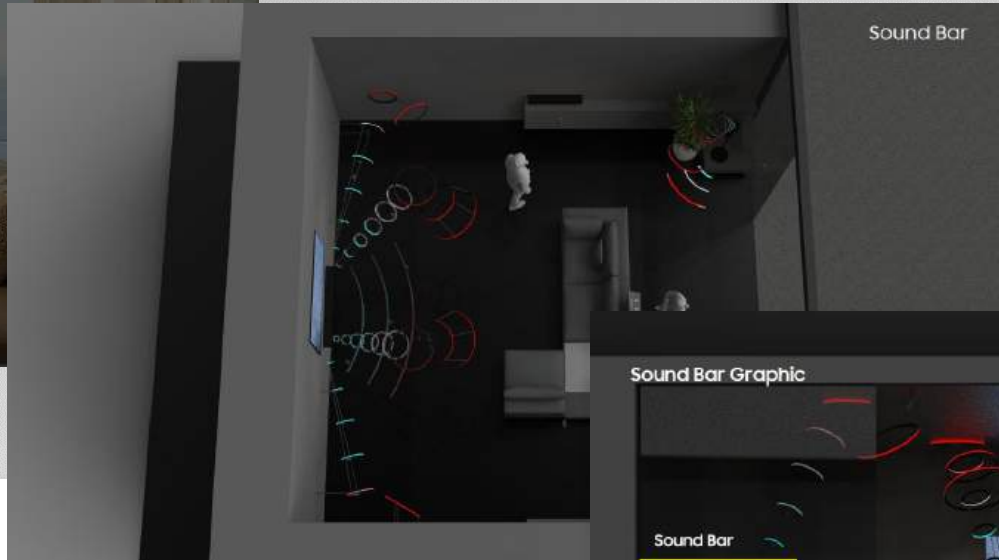
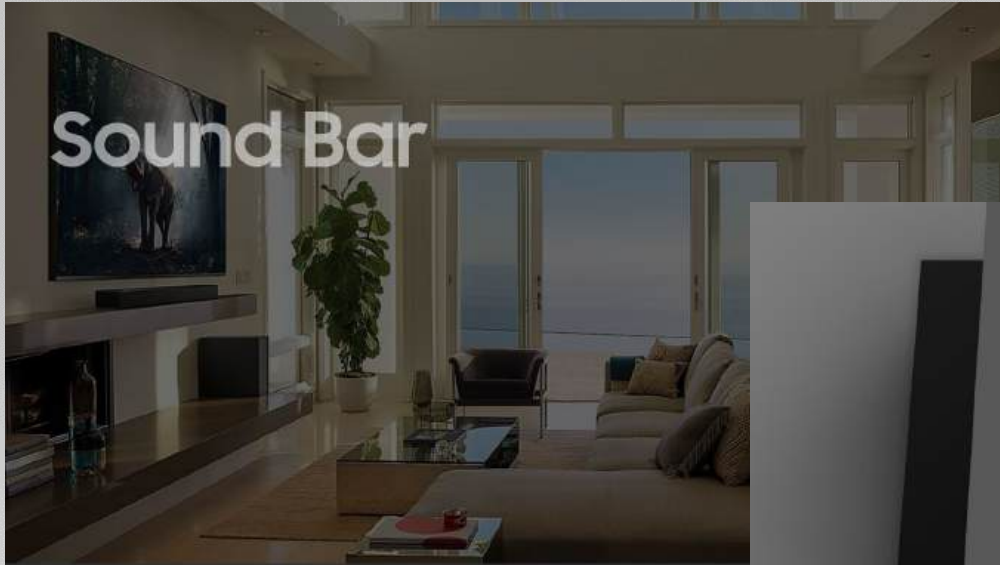

**Sound Bar Graphic**

**Sound Bar**

<p><b>Q90R</b></p> <ul style="list-style-type: none"> <li>True Dolby Atmos, DTS:X support</li> <li>4 Up-firing, 2 Side-firing objective speakers</li> <li>Rear speakers / IP woofer included</li> <li>H/K co-branding</li> <li>7.14Ch</li> </ul>	<p><b>Q80R</b></p> <ul style="list-style-type: none"> <li>True Dolby Atmos, DTS:X support</li> <li>2 Up-firing, 2 Side-firing objective speakers</li> <li>8" woofer included</li> <li>H/K co-branding</li> <li>5.1.2Ch</li> </ul>
<p><b>Q70R</b></p> <ul style="list-style-type: none"> <li>True Dolby Atmos, DTS:X support</li> <li>2 Up-firing Speakers via acoustic beam tech</li> <li>8" woofer included</li> <li>H/K co-branding</li> <li>5.1.2Ch</li> </ul>	<p><b>Q60R</b></p> <ul style="list-style-type: none"> <li>Dolby Digital 5.1 / DTS 5.1</li> <li>acoustic beam tech</li> <li>6.5" woofer included</li> <li>H/K co-branding</li> <li>5.1Ch</li> </ul>

2019 IFA VD Zone  
**Product Solution  
 Design Proposal**

17 JULY 2019



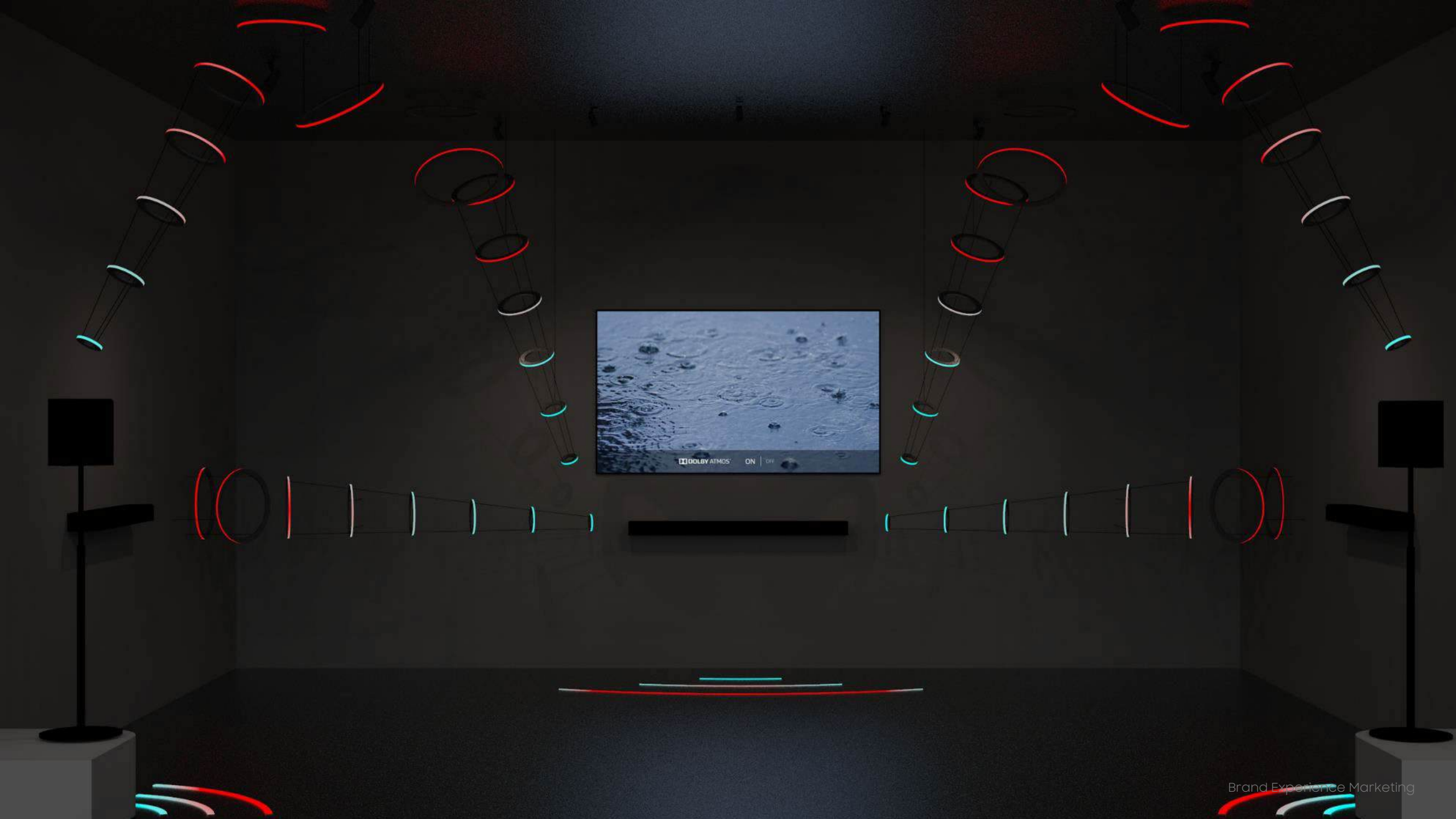

# Q-series Soundbar

Immerse yourself  
with true 7.1.4ch sound



## True 7.1.4ch Sound

Sound moves around and above you with 17 speakers, including four upward-firing and two side-firing.

#1

Samsung #1  
in global  
soundbar sales.



Wireless Rear Speaker Set Included

Wireless Rear Speaker Set includes two wireless  
side-firing speakers and two wireless  
upward-firing speakers with up-firing drivers.

Immerse yourself  
with true 7.1.4ch sound





# Samsung AirDresser Mock UP



# 1 Project Objective

- Show our products (color, form) in intuitive & symbolic way
- Build product mock-up, not product monument, display

A Clothing Cleaner  
beyond the product display

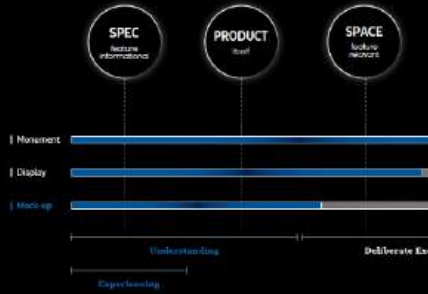

A: B INVISIBLE SHAPE, VISIBLE FUNCTION

Component



A: A VALUE BEYOND DIFFERENCE

Component



## SAMSUNG Clothing Cleaner Mock-up Design Proposal

2018.07.05



# 에어드레서 테크존

"새로운 바람과 스팀의 힘으로 의류 청정 시대를 열다"

## 삼성 에어드레서의 4단계 의류청정

제트에어와 안감케어 옷걸이로 겉과 안 면지를 더 확실하게 털어내고

제트스팀으로 바이러스, 세균까지 살균하고,

뽀송한 드라이는 기본,

미세먼지 필터와 냄새분해 필터로 더 확실하게 제거하는 리얼 청정

삼성 에어드레서

4단계 의류 청정

1. 제트 에어와 안감케어 옷걸이로 겉과 안 면지를 더 확실하게 털어내고

2. 제트스팀으로 바이러스, 세균까지 살균하고, 뽀송한 드라이는 기본,

3. 미세먼지 필터와 냄새분해 필터로 더 확실하게 제거하는 리얼 청정

4. 리얼 청정

미세먼지 필터와 냄새분해 필터로 더 확실하게 제거하는 리얼 청정





# Samsung EuroCuchina 2018 Mock Up

A blurred background image showing a mock-up of Samsung EuroCuchina 2018. The image features several dark-colored kitchen appliances, likely refrigerators or freezers, with glowing blue light strips on their doors. The appliances are arranged in a row, and the background is a light, neutral color.

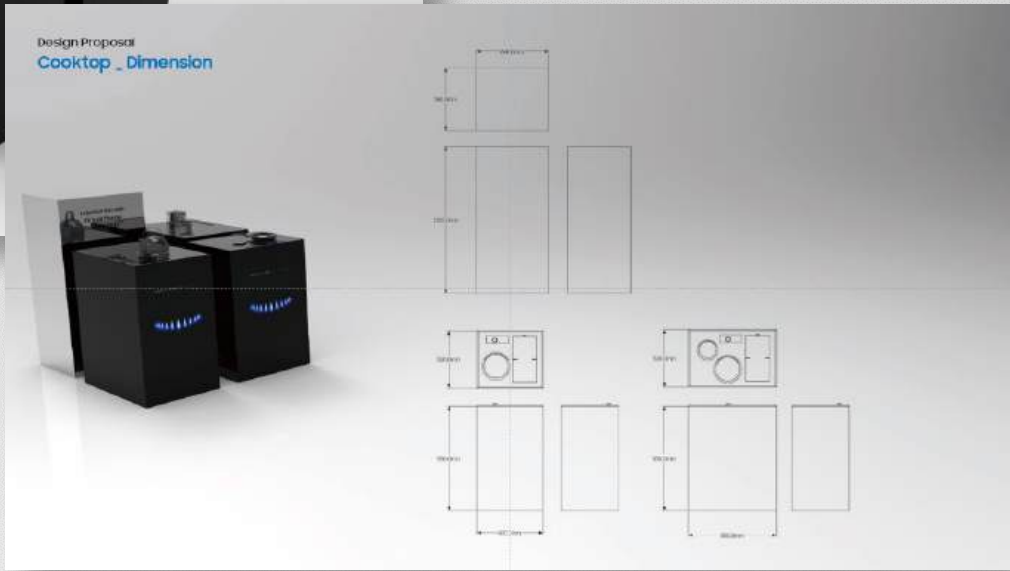
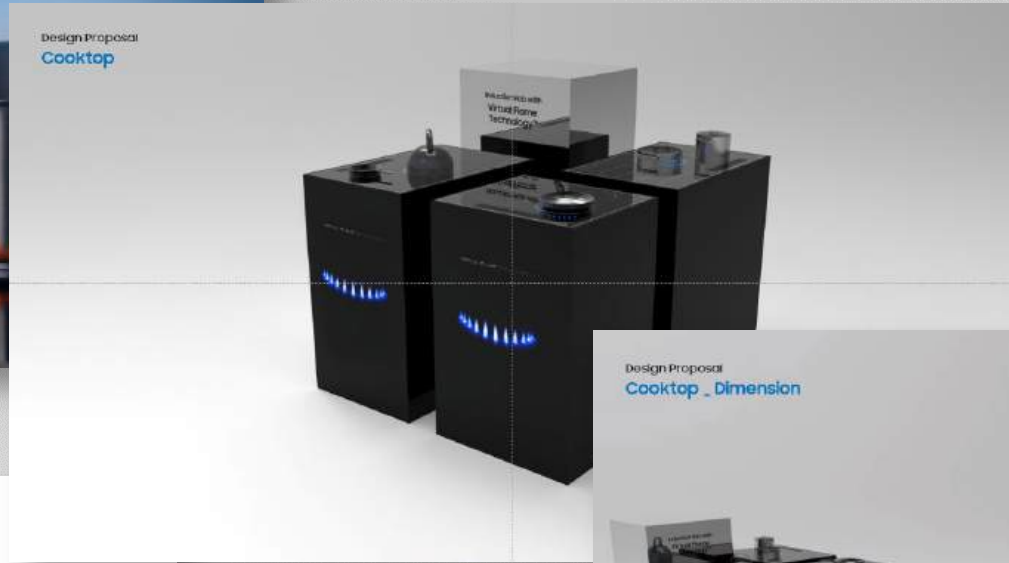

**EuroCucina 2018**  
Samsung Exhibition

**TITLE**  
Eurocucina 2018

**Deliverable Expectation**  
Oven 2/ Dish Washer 1/ Refrigerators 1/ Cooktop 1

**Location**  
Fiera Milano Italy

**Site Spec**  
976,6m<sup>2</sup> (42mX24m)

**Target**  
Exhibitors, Visitors

**Date**  
17th. Apr. - 22th. Apr. 2018 (6Days)

Cooktop



DW



OVEN



RF



Mirror Metal



Induction Hob with  
Virtual Flame  
Technology

VF Mock Up



Black Acrylic Finish  
& Motion Display



Black Podium





## Visual Display Booth highlight development for Samsung Exhibition



# IFA 2018 VD

# HL Zone

QLED 8K

Perfect room  
Home and enter the new era of  
viewing experience



# QLED 8K

## Perfect reality

Bring QLED 8K excitement to your home and enter the new era of viewing experience

Groundbreaking Samsung's new QLED transforms what you love into 8K. Revolutionary technology lets you experience immaculate details in larger screen. Embrace QLED 8K's perfect reality.



Audio Guide

4K



8K



Turn what you love into 8K

Real 8K resolution	QLED 8K	8K TV availability	Available Resolution 8K
7680 x 4320	7680 x 4320	Available	7680 x 4320
3840 x 2160	3840 x 2160	Available	3840 x 2160
1920 x 1080	1920 x 1080	Available	1920 x 1080
1280 x 720	1280 x 720	Available	1280 x 720
640 x 360	640 x 360	Available	640 x 360





## Booth Highlight development for Samsung exhibition



# Goyang Hyundai Motor Studio







WFS 사운드를 감상하세요  
Listen to WFS sound



**GENESIS DH** 0.27cd Aerodynamic Coefficient

주행 안정성과 연비 효율을 추구한 4인승 승용차 형태  
4-door sedan with steady handling and fuel efficiency  
동행자 안전을 위한 크리시스 브레이크 시스템

**Pony** 0.41cd Aerodynamic Coefficient

공기 저항을 낮춰 빠른 주행속도를 추구한 4인승 세드백 형태  
4-door fastback with low air resistance for faster drives  
동행자 안전을 위한 크리시스 브레이크 시스템

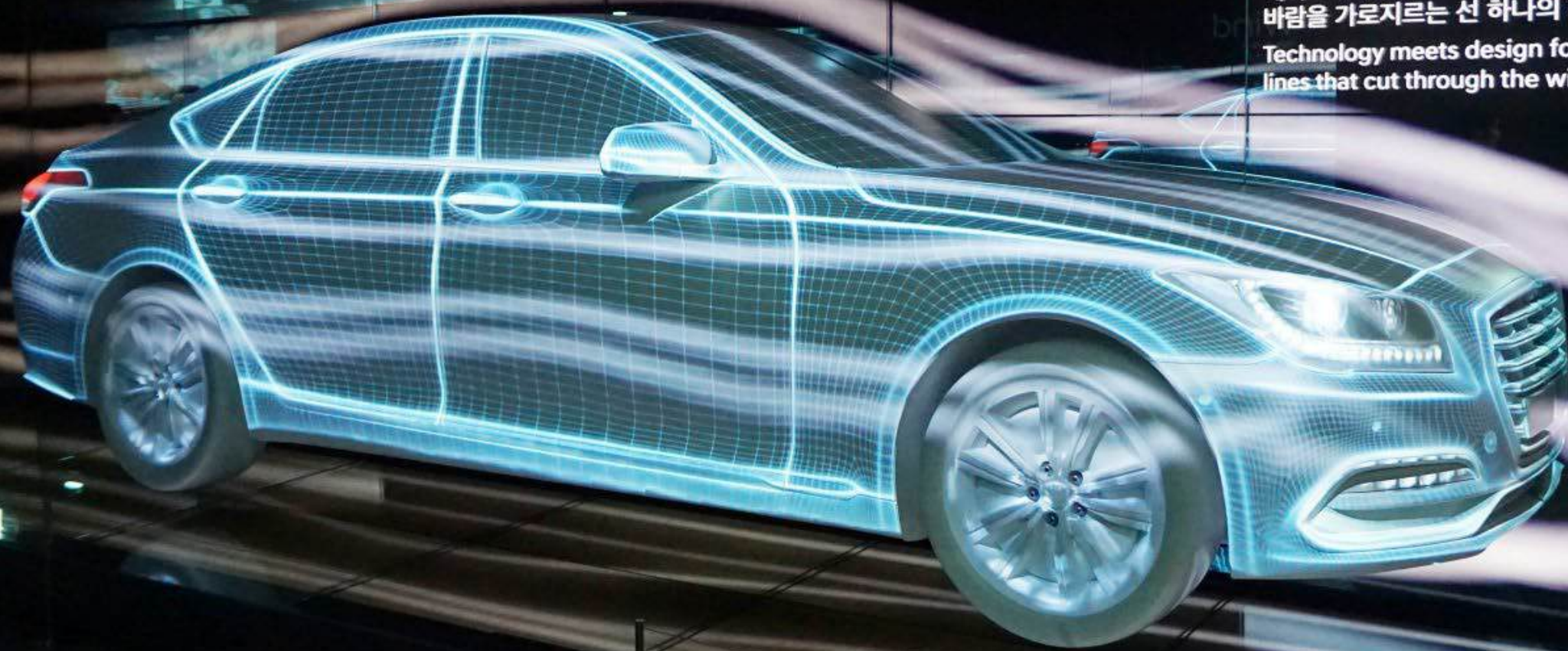

# AERODYNAMIC D

에어로다이내믹 디자인  
바람을 가로지르는 선 하나의 기술  
Technology meets design for  
lines that cut through the wind



# Pyeongchang 2018

# Rethinking

# Samsung



Samsung's  
take-off  
into the  
mobile world



1988

Add-on  
features  
Add-on  
possibilities



1999

Era of  
mobile  
multimedia

2002

Mobile  
innovation  
& revolution

2005

Smart life,  
Smart mobile

2010

Connected  
world  
by Samsung

2018

Samsung's  
take-off into the  
mobile world



of mobile  
multimedia

ation & revolution

Smart life,  
Smart mobile

Connected  
world  
by Samsung





Olympic Games Edition Phone  
**NAGANO 1998**  
Samsung N206



**SYDNEY 2000**

Showcasing the first on-site brand pavilion (Olivis), Samsung unveiled a diverse range of exciting activities of the Olympic Games. 올림픽 현장에 설치된 삼성 올비비스 부스, 다양한 올림픽 활동을 소개함

Olympic Games Edition Phone  
**SYDNEY 2000**  
Samsung SGH-A100



**SALT LAKE CITY 2002**

**ATHENS 2004**

Olympic Torch  
**NAGANO 1998**



Mobile Application

Samsung Reporters

Social Responsibility

Samsung Visual Language



Samsung Pavilion



Samsung Pin Collection  
**NAGANO 1998**



Samsung Pin Collection  
**SYDNEY 2000**



Samsung Pavilion  
**SALT LAKE CITY 2002**



**SALT LAKE CITY 2002**



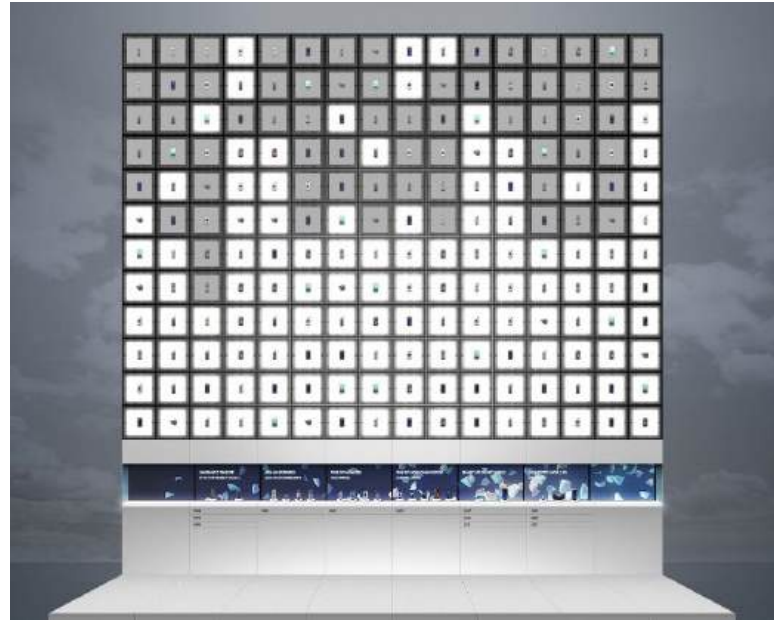
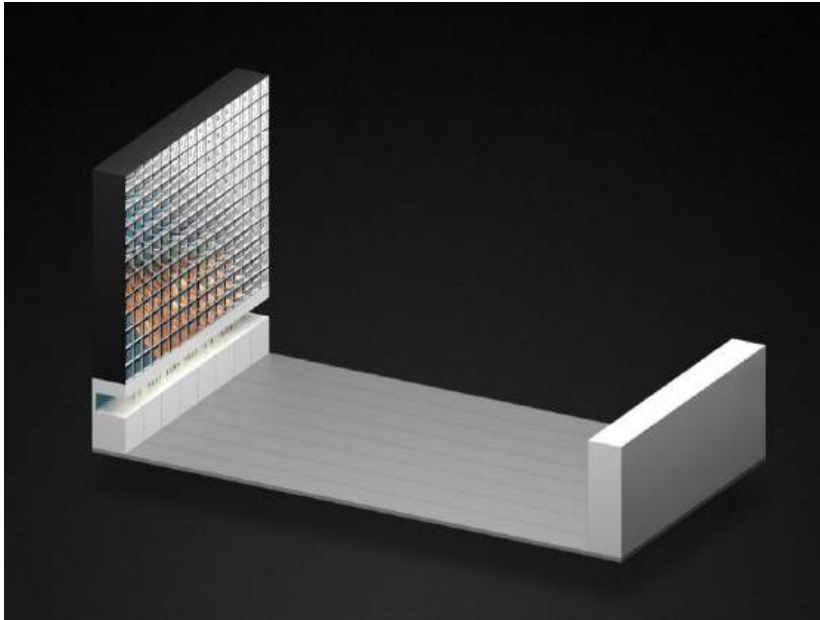

## Media wall development for Samsung Pyeongchang 2018 exhibition

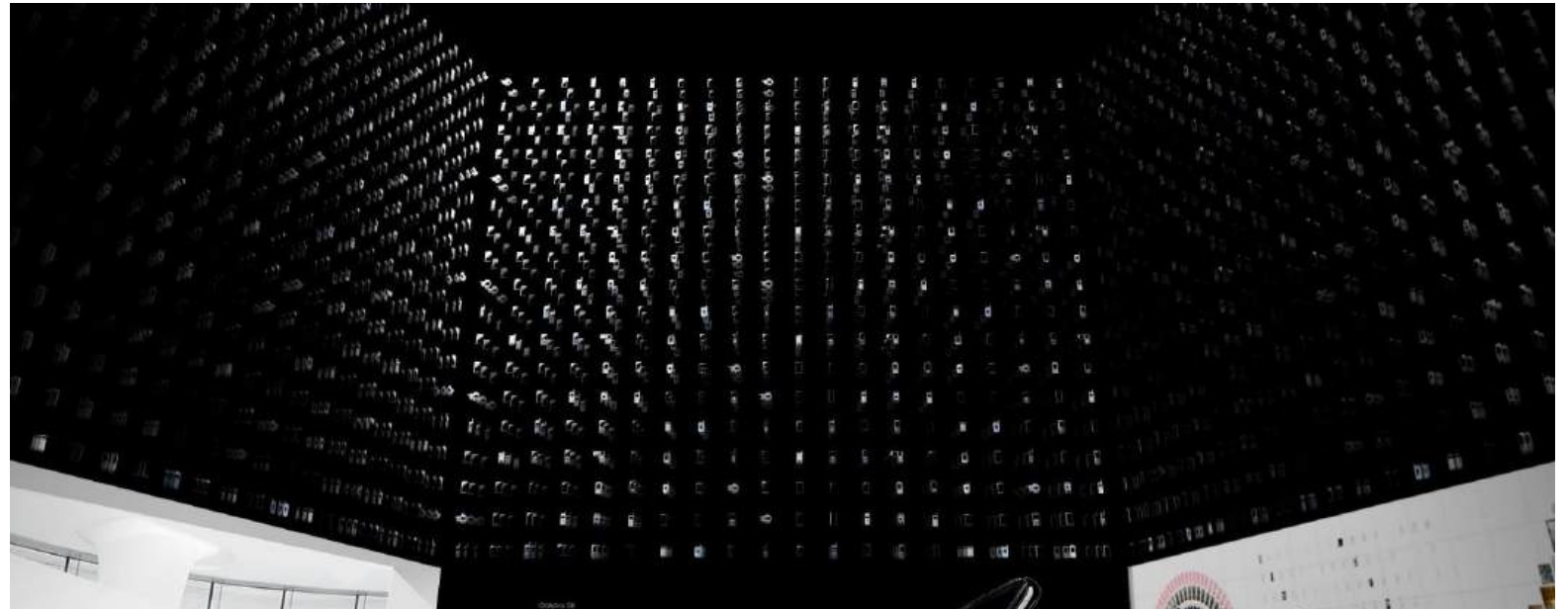

The image shows the exterior of a building with a sign that reads "Ganghwa Southern Kids Play Place". The building has a modern design with a mix of brown, tan, and teal colors. The text "Ganghwa Southern Kids Play Place" is overlaid in large white font. The background is a clear blue sky.

# Ganghwa Southern Kids Play Place



## Interior Design and build up for Ganghwa Southern Kids Play Place







## Models for MMCA Jenny Holzer Exhibition Robotic System

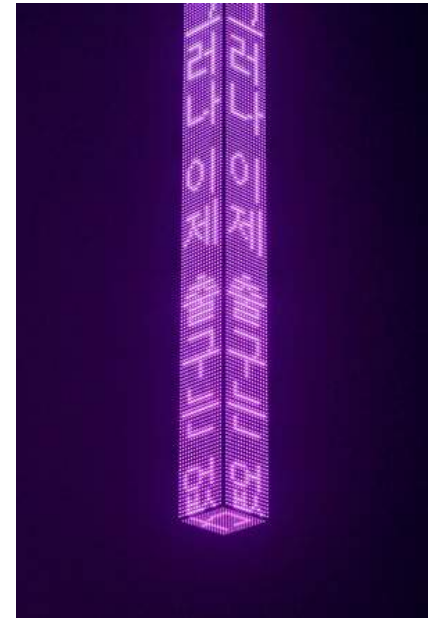
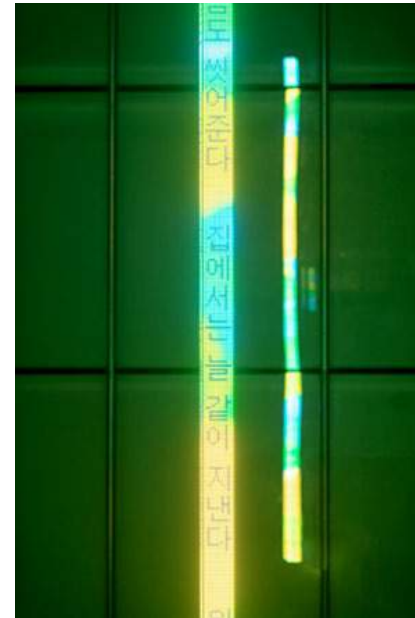
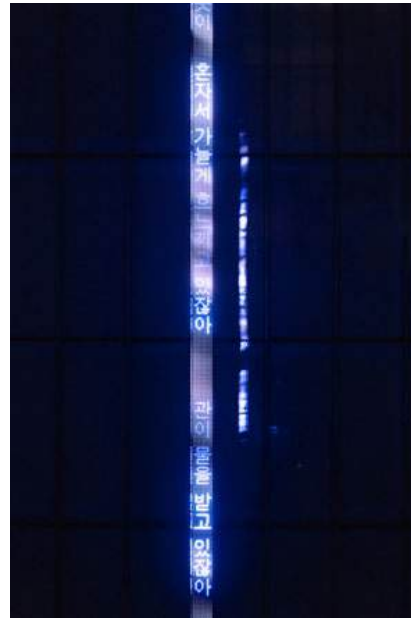



**Models for GWACHEON  
Science Museum  
Korea Military  
Experience Zone**





## Models for GWACHEON Science Museum Makerland



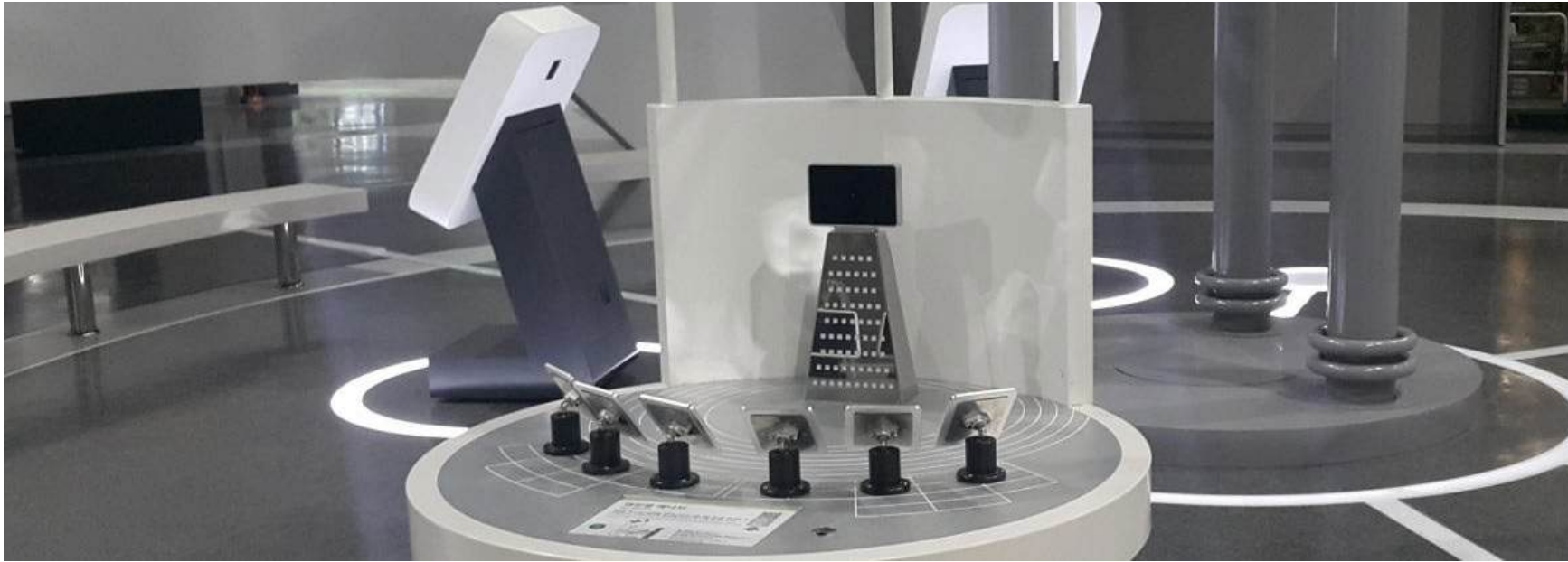

## Model development for National Busan Science Museum Experience





## Car Model development for Kidzania Museum Experience





## Car Model development for Kidzania Museum Experience





## Car Model development for Kidzania Museum Experience





**Oversize marionette  
development for Yeosu EXPO  
symbol**



**Video  
Contents  
Production**

# Hanwha Future Tech Forum 2025

2025 APEC  
CEO SUMMIT  
Hanwha  
Future Tech Forum  
Sustainable Peace for All

2025 APEC  
CEO SUMMIT  
Hanwha  
Future Tech Forum: Defense  
Sustainable Peace for All

KCCI

Ministry of Trade  
and Industry

hanwha

# 2025 한화 퓨처 테크 포럼 | 주제영상

한화 | 제일기획 | 4K | 국내



# 2025 한화 퓨처 테크 포럼 | 스케치 영상

한화 | 제일기획 | 4K | 국내

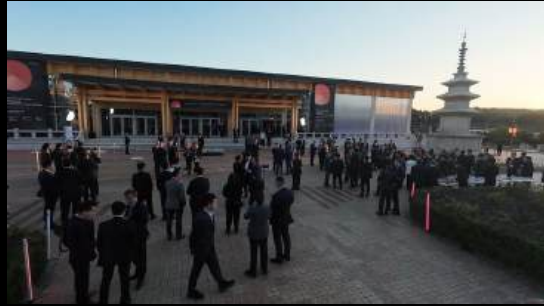

# Hanwha ADEX

# 2025



# 2025 한화 ADEX | Theme Film

한화 | 제일기획 | 8K | 국내



# 2025 한화 ADEX| Zone Highlight Film

한화 | 제일기획 | 4K | 국내



# 2025 한화 ADEX | 스케치 영상

한화 | 제일기획 | 4K | 국내

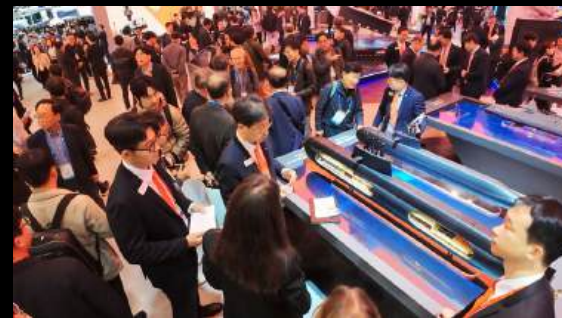

# Hanwha IDEX 2025



# 2025 한화 IDEX | 전관영상

한화 | 제일기획 | 6K | 국외

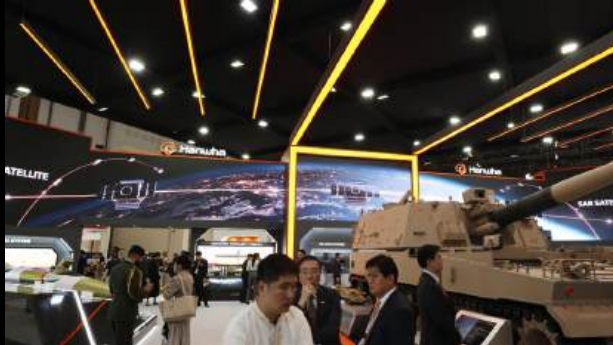

# 2025 한화 IDEX | 스케치 영상

한화 | 제일기획 | FHD | 국외



# Kooksoondang Brand Film 2024



# 2024 국순당 백세주 | 리바이탈 캠페인

국순당 | 제일기획 | FHD | 국내





2024

Google Play

# 2024 Google Play 코드퀘스트 | FC Mobile

구글플레이 코리아 | 제일기획 | FHD | 국내



# Google Play Challenge 2023

A person with long dark hair, wearing a purple cardigan and light-colored pants, is sitting in a yellow office chair at a desk. They are holding a smartphone in their right hand, which has a glowing, multi-colored light effect around it. The desk is cluttered with various items, including a computer monitor displaying a software interface, a keyboard, and a mouse. In the background, there are two large blue speakers on stands and a window with blinds. To the right, a guitar is visible. The overall atmosphere is dimly lit, suggesting an evening or night setting.

# Google Play challenge 2023 | TVCF

Google | 제일기획 | FHD | 국내

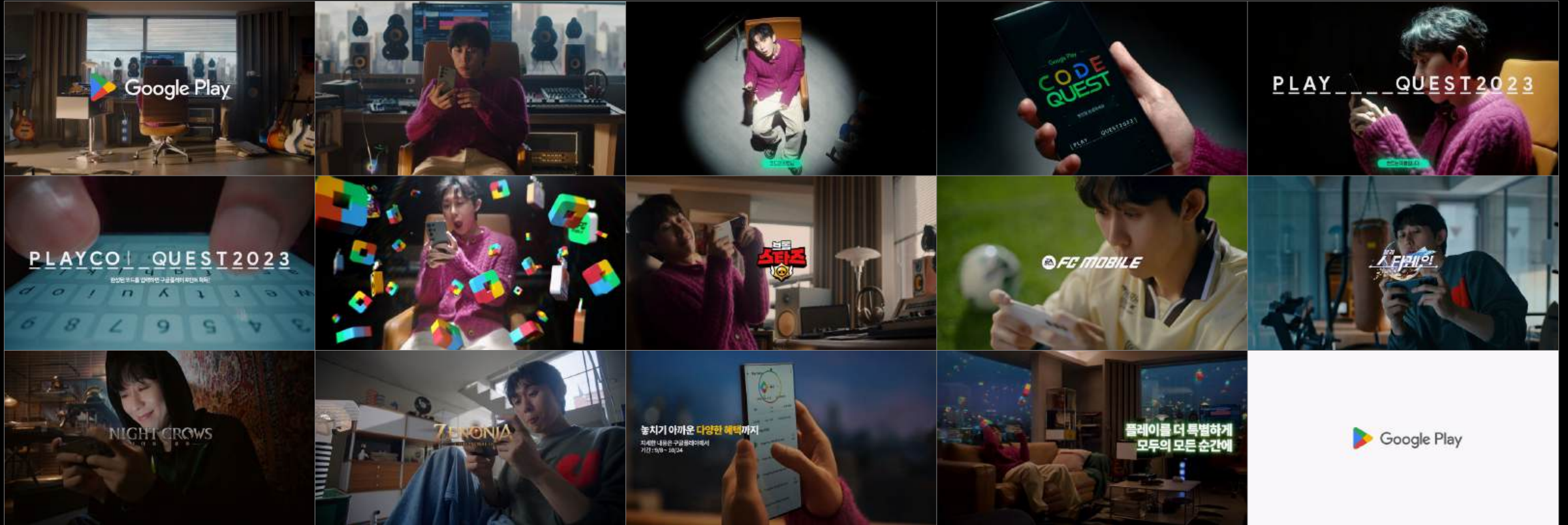

# Diablo 4 Launching Campaign 2023



Spikes Asia



한국광고학회  
Korean Advertising Society

## Diablo 4 Launching Campaign | IP 영상

블리자드 | 제일기획 | FHD | 국내



## Diablo 4 Launching Campaign | DOOH 영상

블리자드 | 제일기획 | FHD | 국내



세로형

정방형

가로형

아나모픽

## Diablo 4 Launching Campaign | 모큐멘터리 영상

블리자드 | 제일기획 | FHD | 국내



## Diablo 4 Launching Campaign | 페이크호러 영상

블리자드 | 제일기획 | FHD | 국내



## Diablo 4 Launching Campaign | 페이크뉴스 1 영상

블리자드 | 제일기획 | FHD | 국내



## Diablo 4 Launching Campaign | 페이크뉴스 2 영상

블리자드 | 제일기획 | FHD | 국내



# Samsung Networks MWC 2023



## Samsung Network MWC 2023 | Core 영상

삼성 | 제일기획 | 4K | 글로벌



## Samsung Network MWC 2023 | Multi-RAT 영상

삼성 | 제일기획 | 4K | 글로벌



## Samsung Network MWC 2023 | UPF 영상

삼성 | 제일기획 | 4K | 글로벌

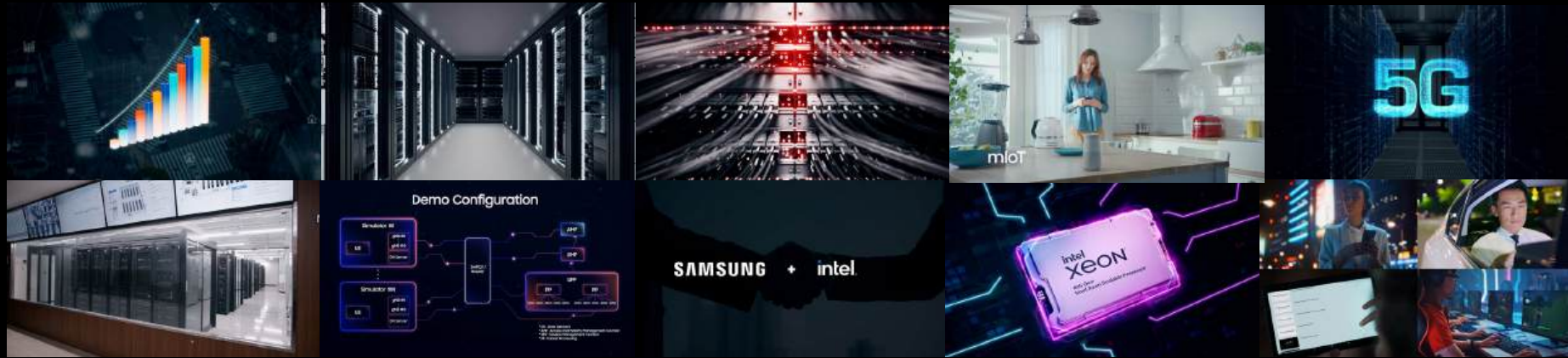

## Samsung Network MWC 2023 | VRAN 영상

삼성 | 제일기획 | 4K | 글로벌

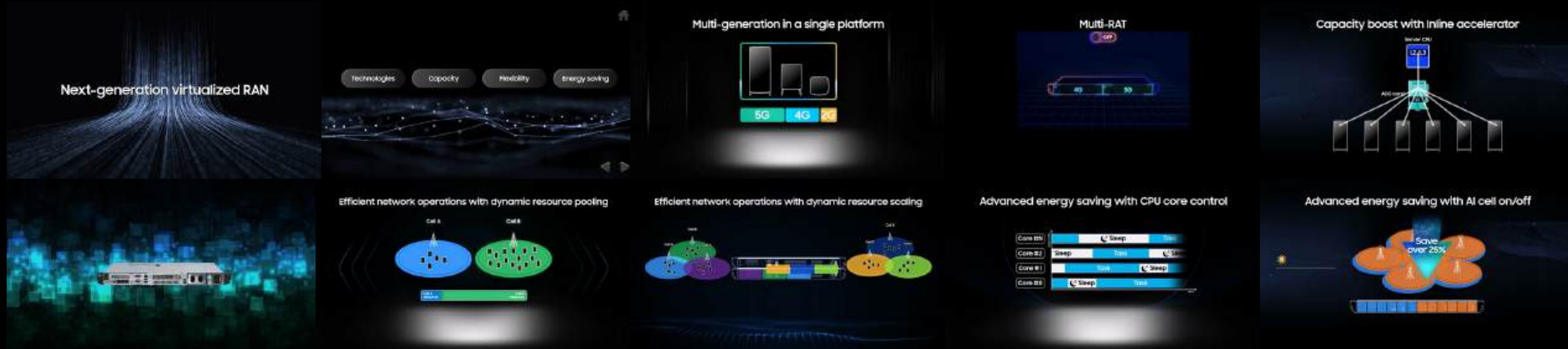

# Samsung Network MWC 2023 | Intro 영상

삼성 | 제일기획 | 4K | 글로벌



# HD HYUNDAI

# CES

# 2023



# HD HYUNDAI CES 2023 | 테마 영상

HD 현대 | 제일기획 | 4K | 글로벌

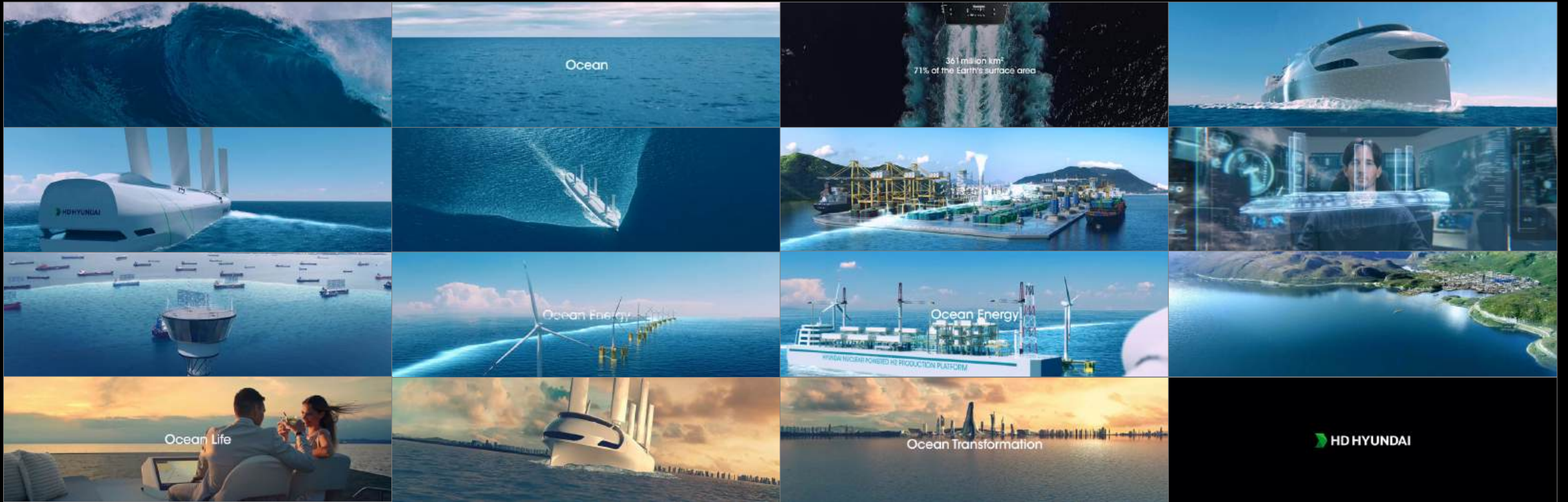

Ocean

361 million km<sup>2</sup>  
71% of the Earth's surface area

HD HYUNDAI

Ocean Energy

Ocean Energy

APACIA NUCLEAR POWERED H<sub>2</sub> PRODUCTION PLATFORM

Ocean Life

Ocean Transformation

HD HYUNDAI

HD HYUNDAI CES 2023 | 브릿지 영상

HD 현대 | 제일기획 | 4K | 글로벌

**OCEANWISE**

OCEAN MOBILITY

OCEANWISE

OCEAN ENERGY

OCEAN LIFE

TRANSFORMATION

HD HYUNDAI

HD HYUNDAI

# Samsung GMC

# CES

# 2023

# Moving Display

SmartThings

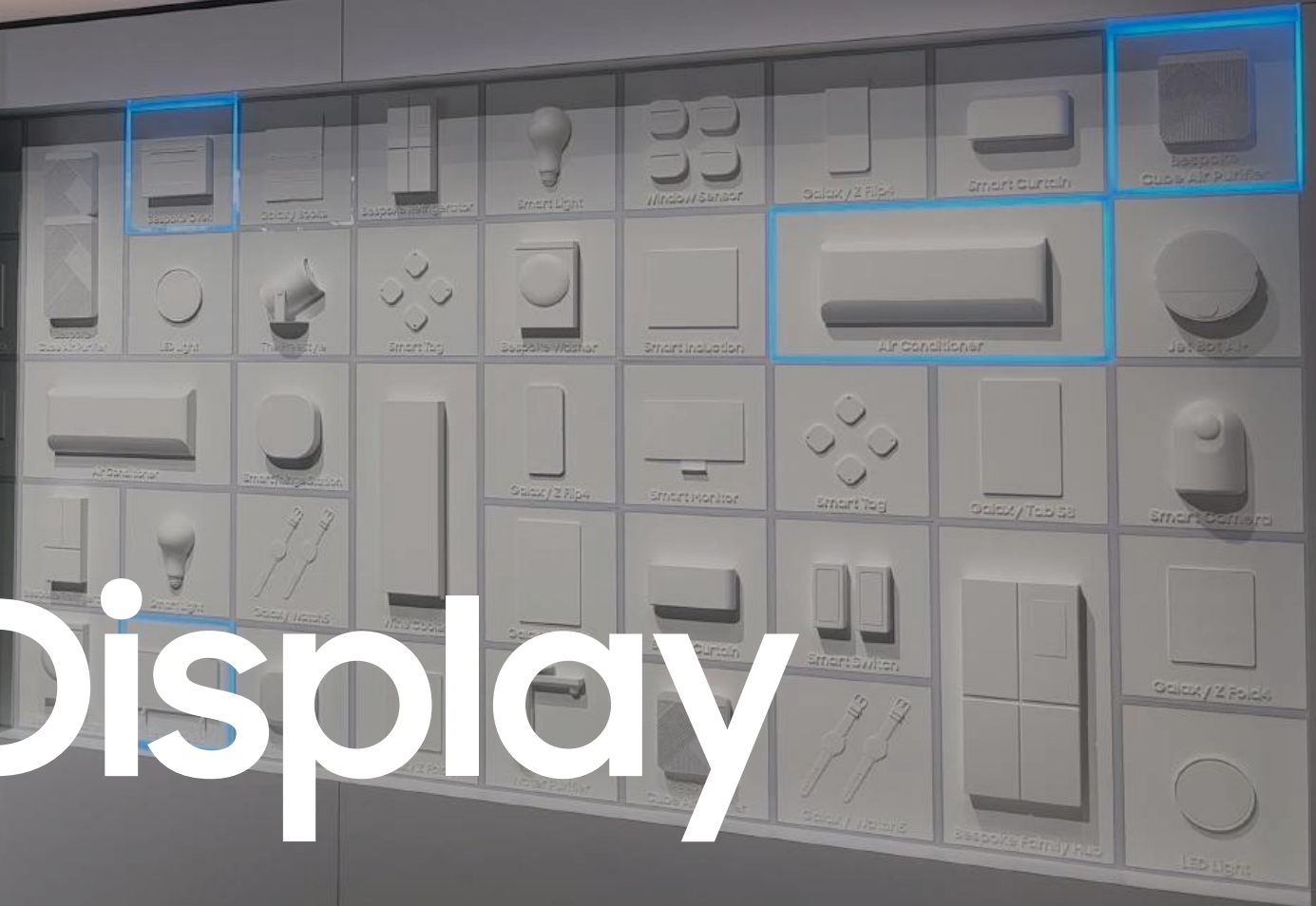

# Samsung GMC CES 2023 | 전시 영상

삼성 | 제일기획 | 4K | 글로벌

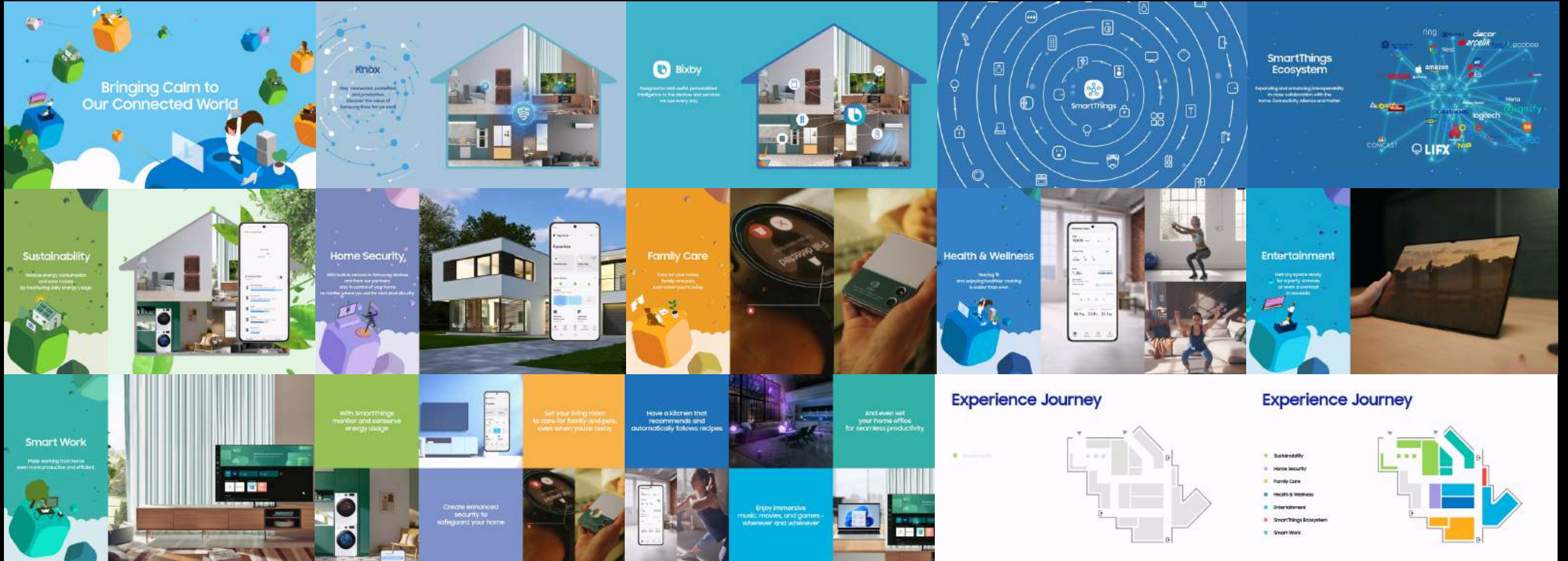

# Samsung Galaxy MWC Event 2022



# Samsung Galaxy MWC Event 2022 | 오프닝 영상

삼성 | 제일기획 | 2K | 글로벌

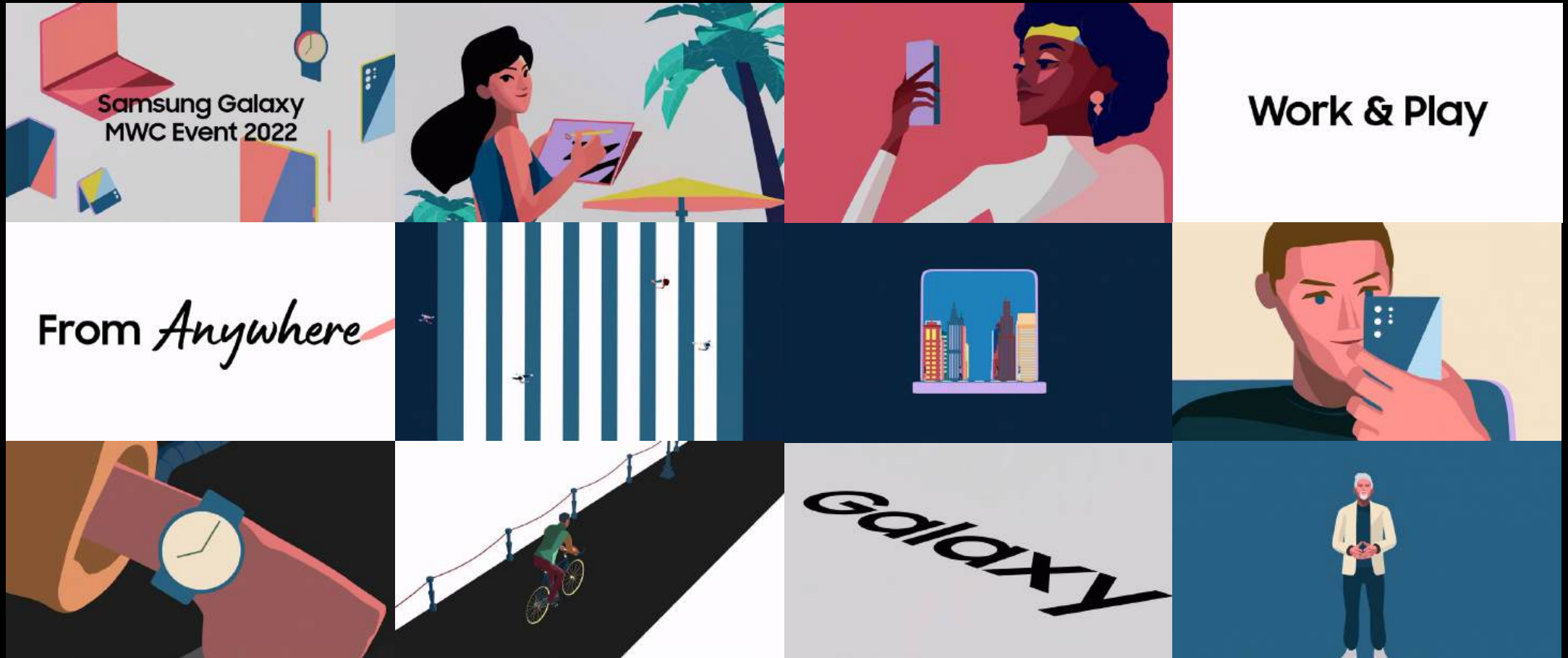

# Samsung Galaxy MWC Event 2022 | 행사 영상

삼성 | 제일기획 | 2K | 글로벌

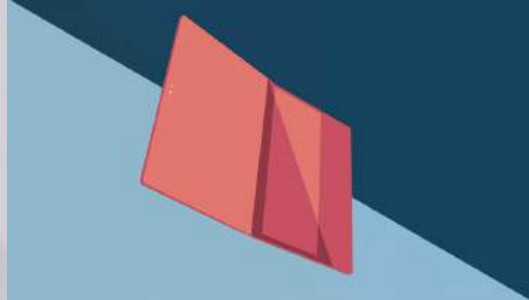

# Galaxy S21FE @2022 CES





# Galaxy S21FE @2022 CES | 행사 영상

삼성 | 제일기획 | 2K | 글로벌

Everyday Epic for Fans

Yoonie Park

# S21 FE

Olive White Graphite Lavender

12MP Ultra-Wide  
12MP Wide  
8MP Telephoto with 3x Zoom

More accurate depth by AI

Incredible detail and clarity

No need for studio

January 11  
Galaxy S21 FE  
from \$699

**Samsung DS**

**CES**

**2022**

**AI Interactive**



# Samsung DS CES 2022 AI Interactive | 인터랙티브 영상

삼성 | 제일기획 | 2432x896 | 글로벌

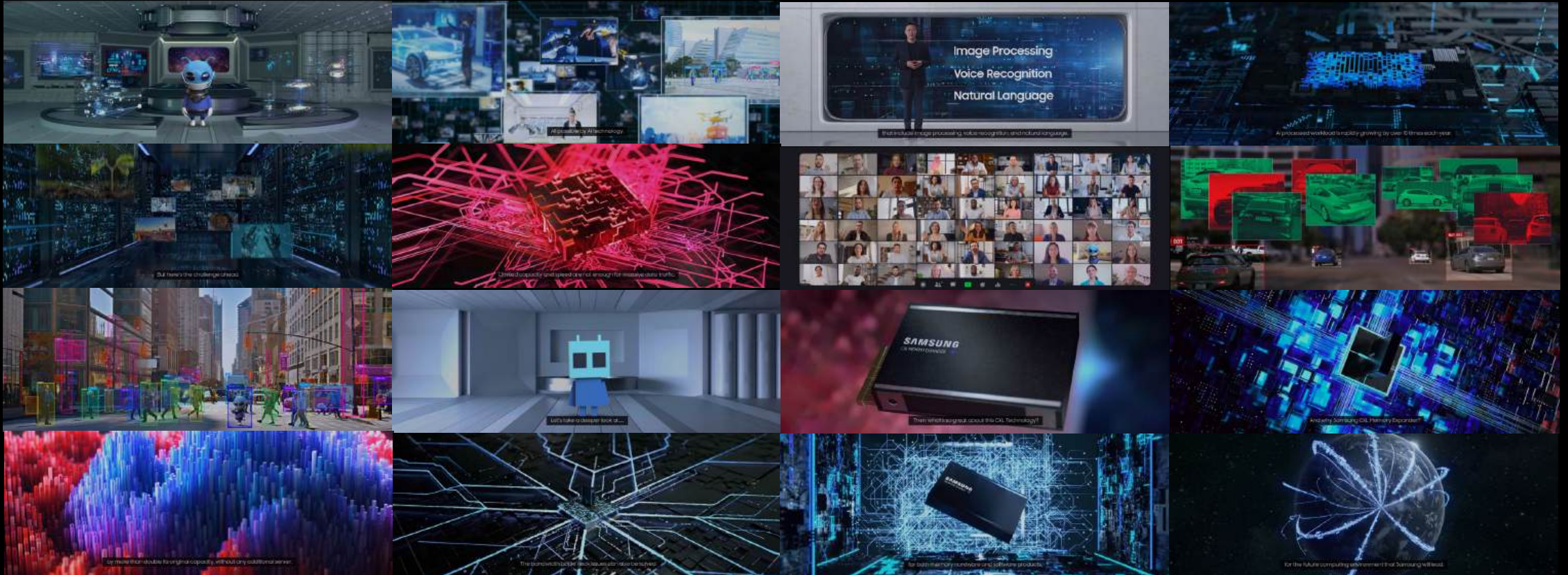

# SDC 2021 Virtual Event



# SDC 2021 Virtual Event | 행사 영상

삼성 | 제일기획 | 4K | 글로벌

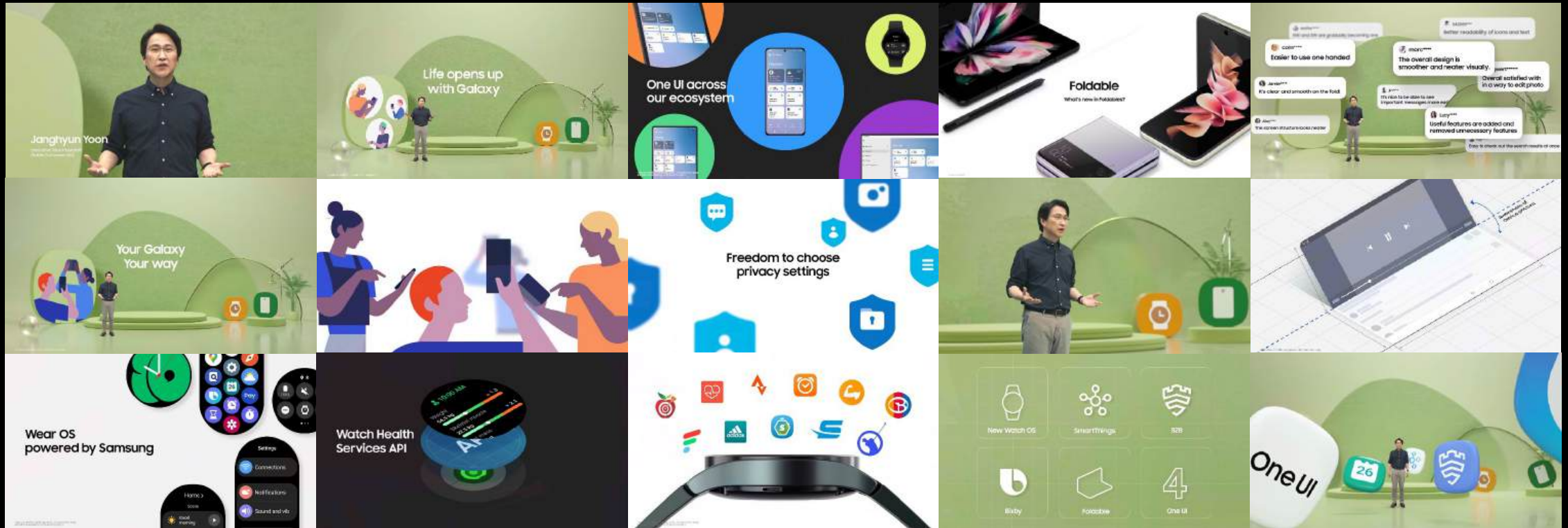

MWC 2021

Galaxy  
Virtual Event



# MWC 2021 Galaxy Virtual Event | 행사 영상

삼성 | 제일기획 | 4K | 글로벌

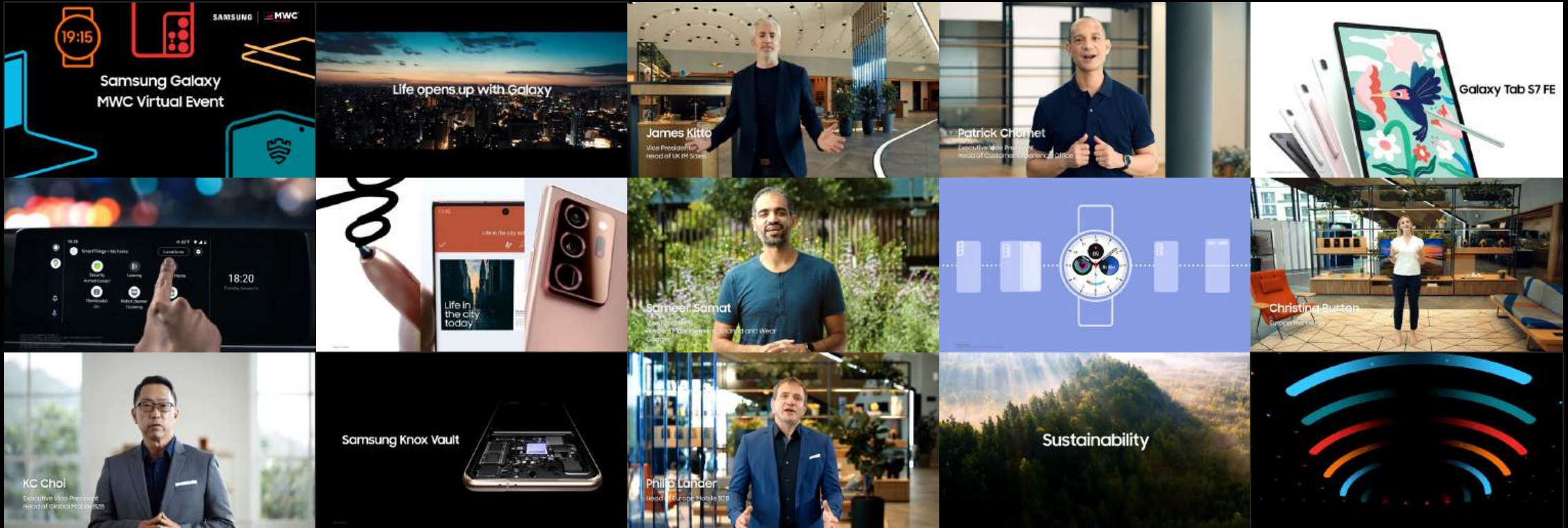

A blurred background image of an office or meeting room. Several people are seated at tables, and a man in a dark suit is standing on the right side of the frame, looking towards the left. The overall scene is out of focus, emphasizing the text overlay.

# 50<sup>th</sup> Anniversary Samsung Commmemoration Video

# 50<sup>th</sup> Anniversary Samsung Commemoration Video | 행사 영상

삼성 | 제일기획 | 2K | 국내





# Samsung DS Introduction of business

# Samsung DS Introduction of business | 홍보 영상

삼성 | 제일기획 | 4K | 국내





# 2020 CES Samsung THE WALL H/L

# 2020 CES Samsung THE WALL H/L | 전시 영상

삼성 | 제일기획 | 8K | 글로벌



**2019 IFA**

**Samsung**

**QLED TV H/L**

SAMSUNG



## 2019 IFA Samsung QLED TV H/L | 전시 영상

삼성 | 제일기획 | 8K X 6 | 글로벌



# Samsung MDE Wall

SAMSUNG



# Samsung MDE Wall | Retail 체험 콘텐츠

삼성 | 제일기획 | 8K X 6 | 글로벌





**HOW**

**T** **O**

**DO**

# OUR PROCESS

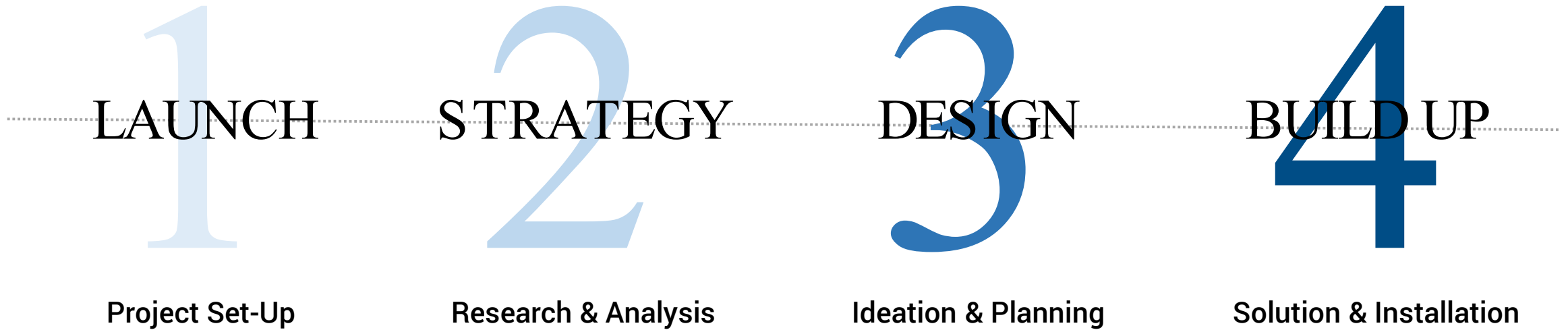

# PLANNING DEP. & DESIGN LAB.

Analyze business and provide creative ideas and solutions  
Proceeds to the pre-production stage and leads the business successfully by communicating.



# PLANNING DEP. & DESIGN LAB.

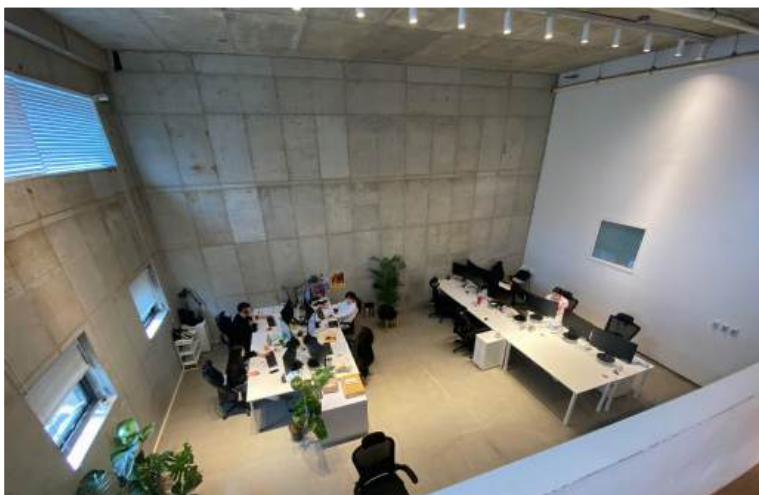

Interactive Product Design



Renewal Design



Visual Design



UI Design



Sculpture Design



Interior Design



Graphic Design



Editor Design



Furniture Design



Exhibition and Space plan



Product Design



VMD

# CONTENTS & S/W DEVELOPMENT



VR



Infinity Mirror



Double Display



Motion Sensor



AR



LED Lighting



Mapping

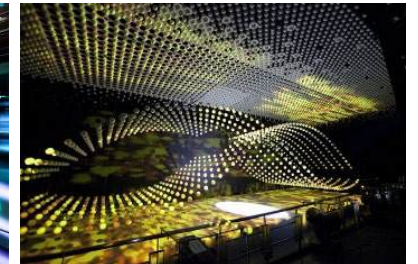

Kinetic Sensor

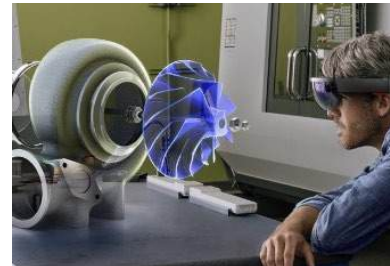

MR



Interactive media



Touch Solution

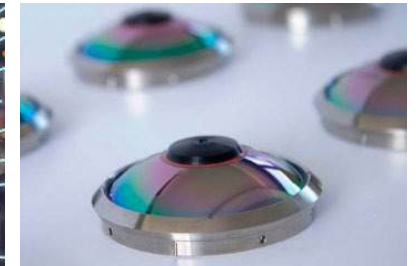

IR Sensor

# MANUFACTURING

A photograph of a manufacturing workshop. In the foreground, a workbench is cluttered with various tools, including a yellow power drill, a box labeled 'SEOVEON CUP', and several small containers. A green plastic crate and a yellow bin are on the floor beneath the workbench. In the background, a large, multi-tiered metal frame structure, possibly a conveyor system or a large machine, dominates the scene. To the right, a silver step ladder stands near a closed metal roll-up door. The workshop is well-lit by overhead lights, and the floor is a light-colored concrete.

The process of producing merchandise by using Resources like labor, machines, tools, raw materials, chemicals and others is known as manufacturing.

# PRODUCTION

Production is a process of making something used for consumption by combining various resources, a form of output is goods and services.



# INSTRUMENT DESIGN SYSTEM CONTROL

A control system is a set of mechanical or electronic devices that regulates other devices or systems by way of control loops.

CREATIVE IDEA  
& TECHNOLOGY  
ARE MAKES  
DIFFERENCE

# PROCUREMENT BUSINESS MANAGEMENT SUPPORT

Procurement is the sourcing and purchasing of goods and services for business use from an external source, preparing tools for communicate with clients.

# MANUFACTURING\_BMT



Painting



Film Coating



Protective film Coating

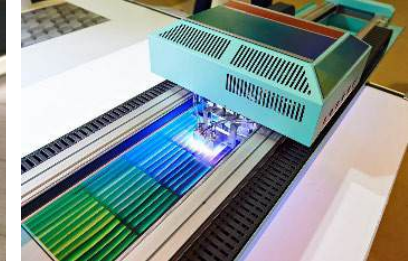

UV Printing



Sheet Cutting



Acrylic Assembly



Motion device Assembly



Welding

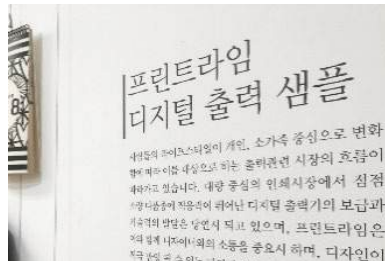

시트지 부착



Anodizing

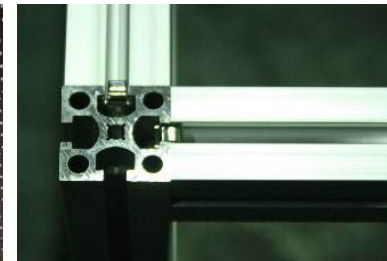

Assemble the Profile

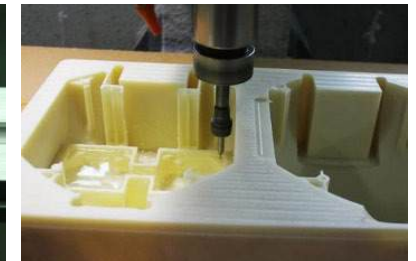

ABS Processing

# MANUFACTURING\_cco



CNC Machining



Galvanized sheet processing



Tapping Machine

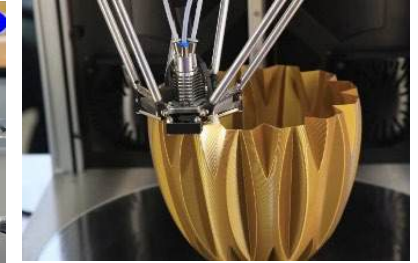

3D Printer

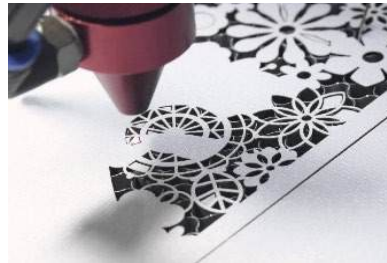

Laser Processing

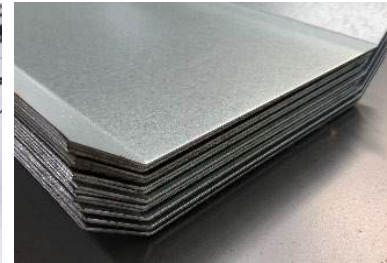

Stainless steel processing



Lathe machine



Drilling Machine(Borubang)

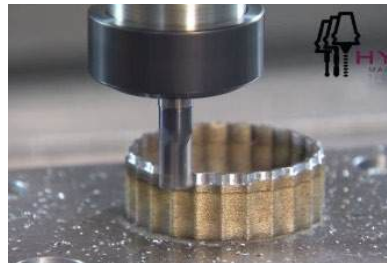

3D Machine



Glass Processing

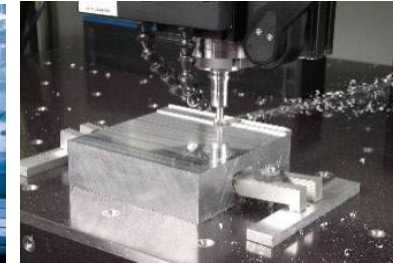

Milling Machine



FRP Processing

# SHOW ROOM

A modern showroom with several interactive displays. In the foreground, there is a racing simulator with a track, a 'START' button, and two small cars. Behind it, there are several white display units with large screens showing various scenes, including a landscape with a sunset and a cityscape. The room has large windows in the background, and the overall atmosphere is bright and clean.

Showroom to collect products  
Serves as a corporate archive  
and the history museum, also  
It can provide tangible result  
and visual when customers visit.

**EOD**